

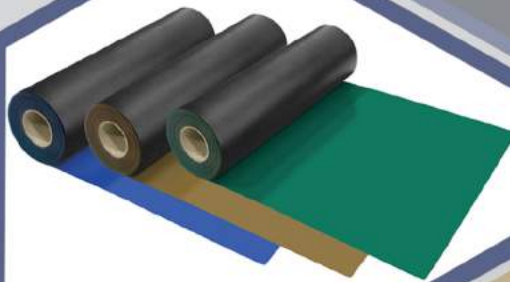

ALIMEX ELECTRONICS

S. A. D E C. V.

ALUMINUM PROFILE



MODULAR RACKING SYSTEMS



ESD AND CLEANROOM PRODUCTS



Av Camino Real a Colima #100 Int. 14-B
Col. Los Cajetes C.P. 45234 Zapopan, Jal.
Tel. (33) 3804-1219
ventas@ameri-links.com

ALI Modular Racking System



SS Conductive Nico Pipe: 28mm x 4m



KW101-28RN
SS Nico Pipe
 28mm x 4m
 Thickness Available:
 0.7, 0.8, 1.0 & 1.2 mm



KW101-28BK-ESD
ESD Black Coated Pipe
 28mm x 4m



ABS Plastic Coated Pipes
 28mm x 4m

KW101-28BL: Blue
KW101-28GY: Gray
KW101-28GR: Green
KW101-28Ivory: Ivory



ABS Plastic Coated Slide Pipe
 28mm x 4m

SS PIPE

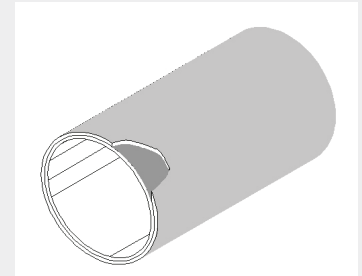

SUS Rolling Pipe

Benefits of SS Nico Pipe

- 1) 100% Recyclable
- 2) High Strength and Durability
- 3) Oil and Chemical Resistance
- 4) Suitable for Cleanroom Applications
- 5) Conductive

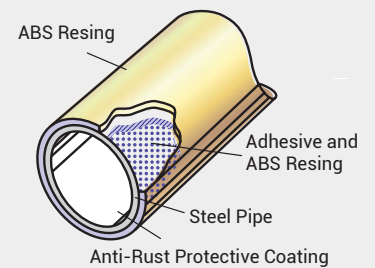

Benefits of Coated Pipe

- 1) Various Colors Available
- 2) Chemical Resistance
- 3) Economical
- 4) Excellent Durability
- 5) ESD in Black Color

Part Number	Type	Ø	Color	Weight	Length	HV
KW101-28RN-.07	SS Pipe	28	Silver	460g/m	4m	210
KW101-28RN-.08	SS Pipe	28	Silver	520g/m	4m	210
KW101-28RN-1.0	SS Pipe	28	Silver	755g/m	4m	210
KW101-28RN-1.2	SS Pipe	28	Silver	780g/m	4m	210
KW101-28BK-ESD	Coated ESD Pipe	28	Black	700g/m	4m	90
KW101-28Ivory	Coated Pipe	28	IV, GR, BL	700g/m	4m	90
KW101-28FL	Slide Pipe	28	IV, GR, BL	770g/m	4m	90
KW101-32RN	STS Pipe	28	Silver	660g/m	4m	210

ALI Black Coated Metal Connectors for 28mm Pipe

B-01



B-02



SPECIFICATIONS

Materials	SPCC-1 (2.6t)
Weight	275g/ea AVG
Plating	Nickel /Zinc /Black

B-03



B-04



B-05



B-06



B-07



B-07A



B-08



B-09



B-10



ALI Black Coated Metal Connectors for 28mm Pipe

B-11



B-12



B-13A



B-13B



B-14A



B-14B



B-15



B-16



B-17



B-17A



B-18



B-19



B-20













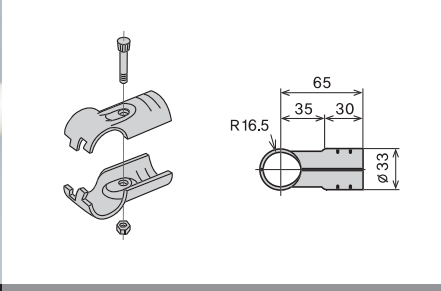

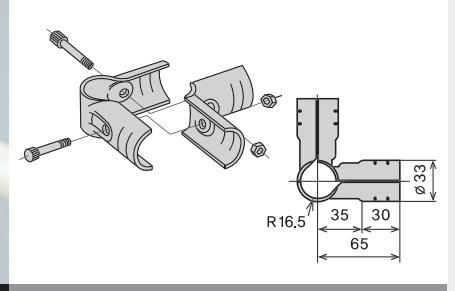

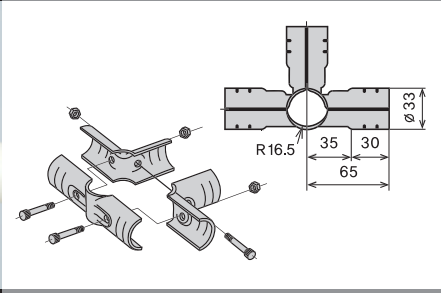
B-21A

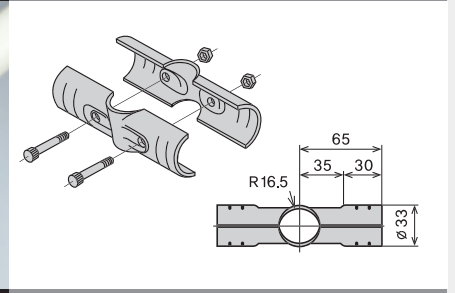

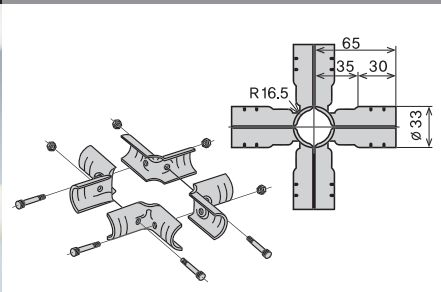
B-21B

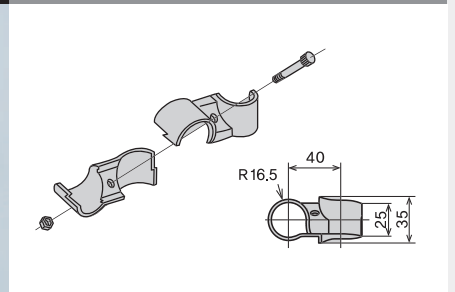

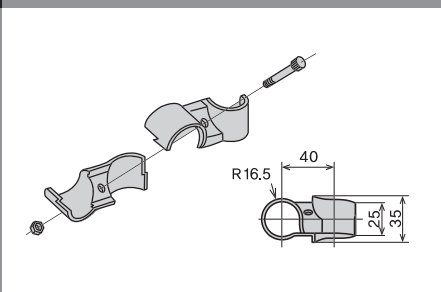
ALI Black Coated Metal Connector-Sets for 28mm Pipe

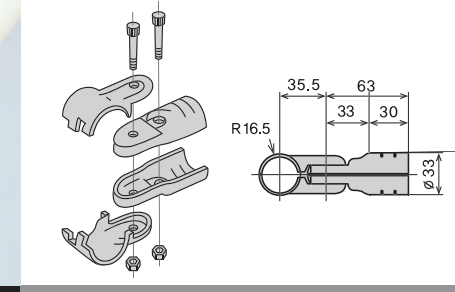
<p>BJ-1</p> 	<p>B-1: 2Pcs Bolt and nut: 1 set</p> 	<p>BJ-2</p> 	<p>B-2: 1Pc B-3: 1Pc Bolt and nut: 2 sets</p> 
<p>BJ-3</p> 	<p>B-2: 2Pcs B-4: 1Pc Bolt and nut: 3 sets</p> 	<p>BJ-4</p> 	<p>B-4: 2Pcs Bolt and nut: 2 sets</p> 
<p>BJ-5</p> 	<p>B-2: 4Pcs Bolt and nut: 4 sets</p> 	<p>BJ-6</p> 	<p>B-7: 2Pcs Bolt and nut: 1 set</p> 
<p>BJ-6A</p> 	<p>B7A: 2Pcs Bolt and nut: 1 set</p> 	<p>BJ-7</p> 	<p>B-5: 2Pcs B-6: 2Pcs Bolt and nut: 2 sets</p> 

ALI Black Coated Metal Connector-Sets for 28mm Pipe

BJ-8

B-8: 2Pcs B-6: 4 Pcs
Bolt and nut: 4 sets

BJ-9

B-9: 2Pcs Bolt and nut: 1 set

BJ-10

B-10: 2Pcs Bolt and nut: 1set

BJ-11

B-11: 2Pcs Bolt and nut: 1set
Plastic Bushing

BJ-12

B-12: 2Pcs Bolt and nut: 1 set

BJ-13

B-13A: 2Pcs B-13B: 2Pcs
Bolt and nut: 1 set

BJ-14

B-14A: 1Pc B-14B: 2Pcs
Bolt: 1 Pc (M6 x 10)

BJ-15

B-15: 2Pcs Bolt and nut: 1 set

ALI Black Coated Metal Connector-Sets for 28mm Pipe

BJ-16 B-16: 2Pcs Bolt and nut: 1 set

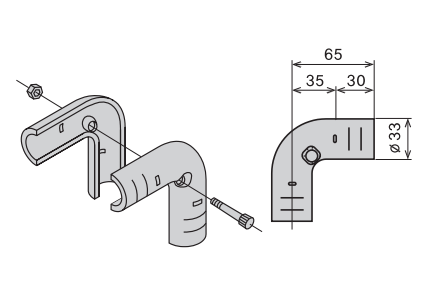
BJ-17 B-17: 2Pcs Plastic Bushing: 2Pcs
Bolt and nut: 1 set

BJ-17A B-17A: 2Pcs Plastic Bushing: 1Pc
Bolt and nut: 1 set

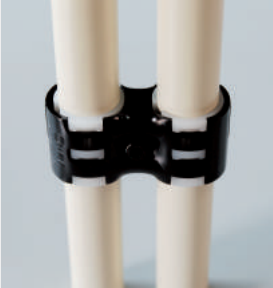
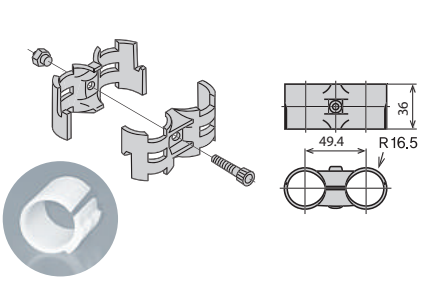
BJ-18 B-18: 2Pcs Bolt and nut: 1 set

BJ-19 B-19: 2Pcs Bolt and nut: 1 set

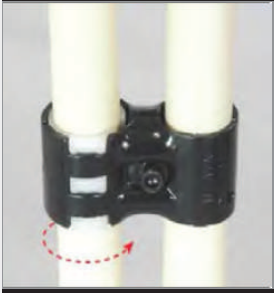
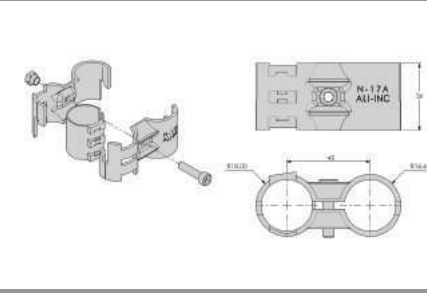
BJ-20 B-20: 2Pcs Bolt and nut: 1 set

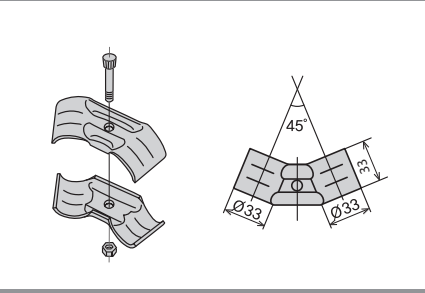

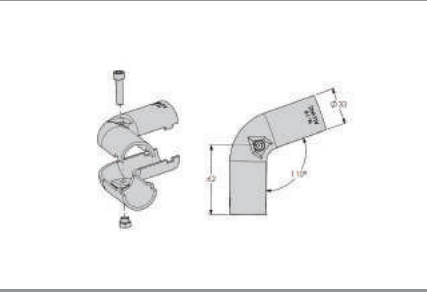

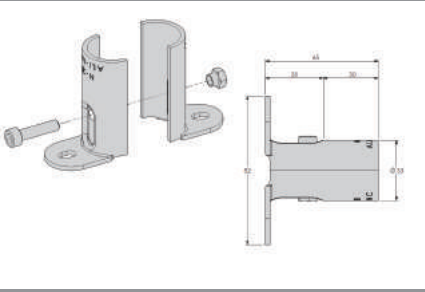
BJ-21 B-21A: 1Pc B-21B: 1Pc
Bolt and nut: 1 set

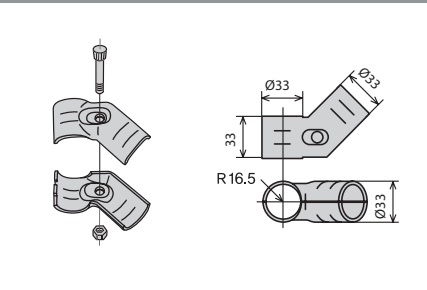
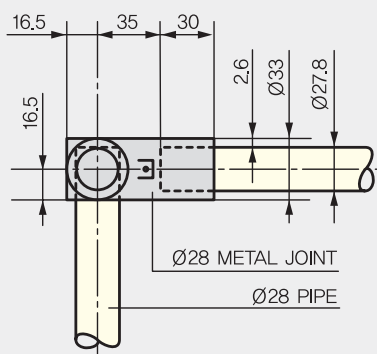

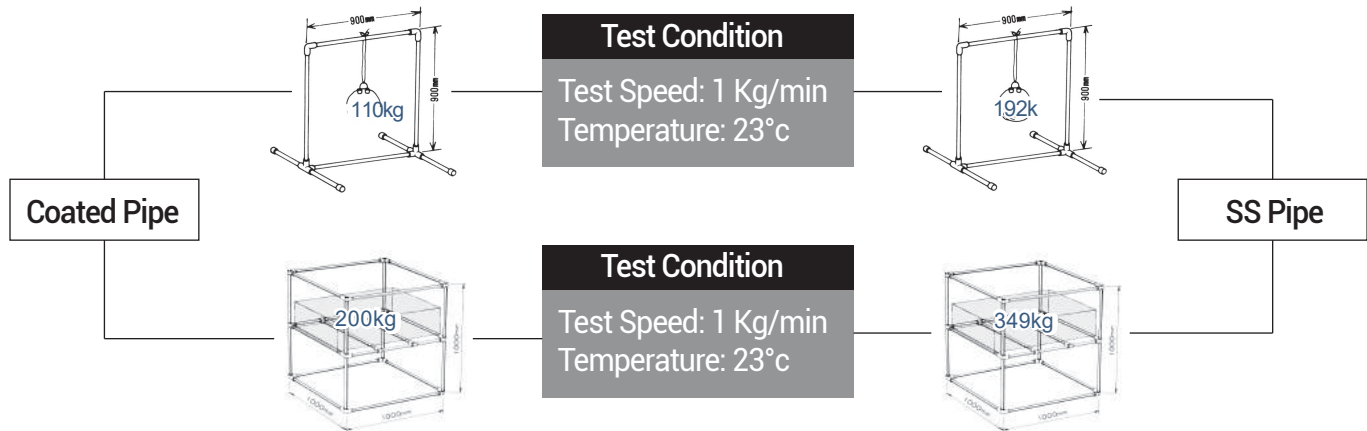

ALI 28mm Pipe Load Capacity

Pipe Load Capacity

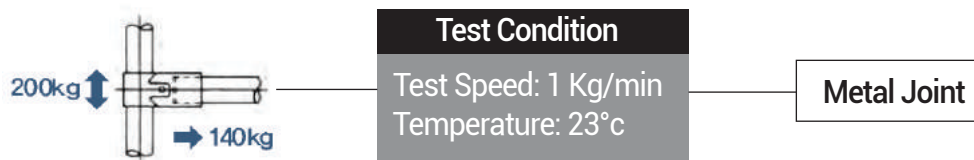

Metal Joint Set Load Capacity



Conveyor Frame Load Capacity

Conveyor Type	Roller dia.	Length	Load
40 Type	33	1,000 mm	130 kgf
60 Type	16	1,000 mm	150 kgf
80 Type	35	1,000 mm	250 kgf
Test Condition	Test Speed: 5 mm/ min - Temperature: 23°C		

Conveyor Roller Load Capacity

Conveyor Type	Roller dia.	Load
40 Type	33	170 kgf
60 Type	16	240 kgf
80 Type	35	270 kgf
Test Condition	Temperature: 23°C	

ALI Conductive Metal Connectors for 28mm Pipe

N-1



N-2



SPECIFICATIONS

Materials	SPCC-1 (2.6t)
Weight	275g/ea AVG
Plating	Nickel /Zinc /Black

N-3



N-4



N-5



N-6



N-7



N-7A



N-8



N-9









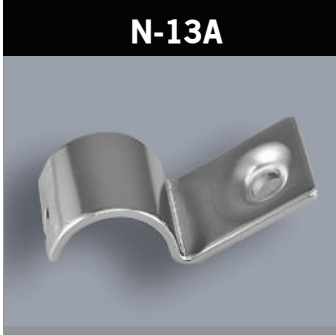



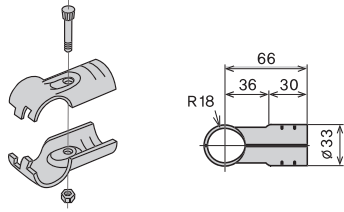

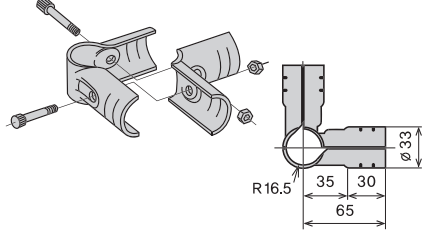

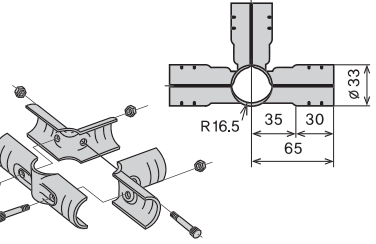
N-10

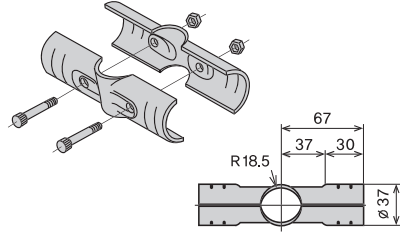

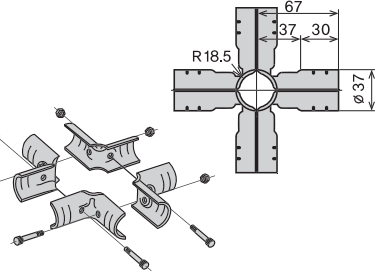
ALI Conductive Metal Connectors for 28mm Pipe

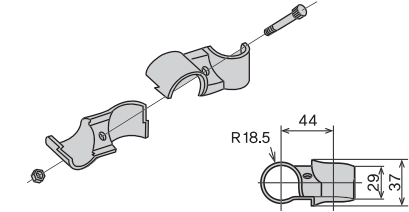

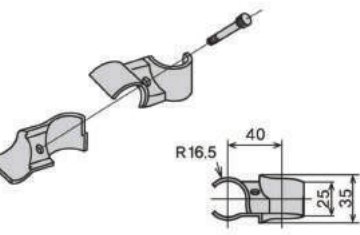
ALI Conductive Metal Connectors for 28mm Pipe-Sets

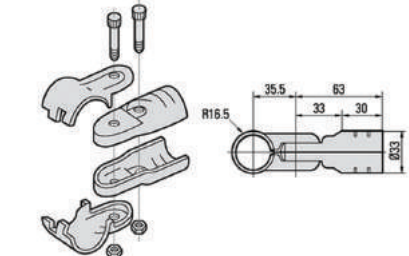
<p>NJ-1</p> 	<p>N-1: 2Pcs Bolt and nut: 1 set</p> 	<p>NJ-2</p> 	<p>N-2: 1Pc N-3: 1Pc Bolt and nut: 2 set</p> 
<p>NJ-3</p> 	<p>N-2: 2Pcs N-4: 1Pc Bolt and nut: 3 set</p> 	<p>NJ-4</p> 	<p>N-4: 2Pcs Bolt and nut: 2 sets</p> 
<p>NJ-5</p> 	<p>N-2: 4Pcs Bolt and nut: 4 sets</p> 	<p>NJ-6</p> 	<p>N-7: 2Pcs Bolt and nut: 1 set</p> 
<p>NJ-6A</p> 	<p>N-7A: 2Pcs Bolt and nut: 1 set</p> 	<p>NJ-7</p> 	<p>N-5: 2Pcs N-6: 2Pcs Bolt and nut: 2 sets</p> 

ALI Conductive Metal Connectors for 28mm Pipe-Sets

NJ-8 N-8: 2Pcs N-6: 4Pcs
Bolt and nut: 2 sets

NJ-9 N-9: 2Pcs Bolt and nut: 1 set

NJ-10 N-10: 2Pcs Bolt and nut: 1 set

NJ-11 N-11: 2Pcs Bolt and nut: 1 set
Plastic Bushing

NJ-12 N-12: 2Pcs Bolt and nut: 1 set

NJ-13 N-13A: 2Pcs N-13B: 2Pcs
Bolt and nut: 1 set

NJ-14 N-14A: 1Pc N-14B: 1Pc
Bolt : 1 Pc (M6 x10)

NJ-15 N-15: 2Pcs Bolt and nut: 1 set

ALI Conductive Metal Connectors for 28mm Pipe-Sets

NJ-16

N-16: 2Pcs Bolt and nut: 1 set

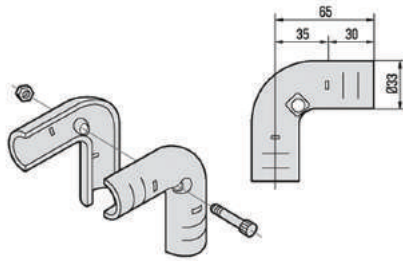

NJ-17

N-17: 2Pcs Bolt and nut: 1 set
1 Plastic Bushing

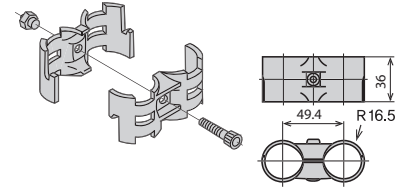

NJ-17A

N-17A: 2Pcs Bolt and nut: 1 set
1 Plastic Bushing

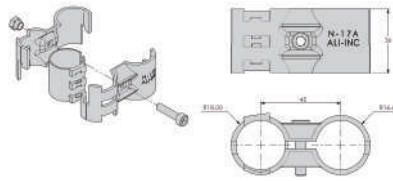

NJ-18

N-11: 2Pcs Bolt and nut: 1 set

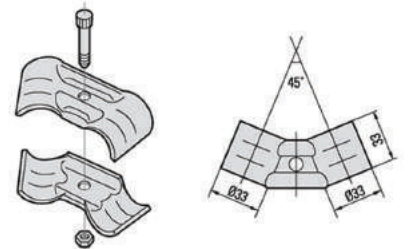

NJ-19

N-19: 2Pcs Bolt and nut: 1 set

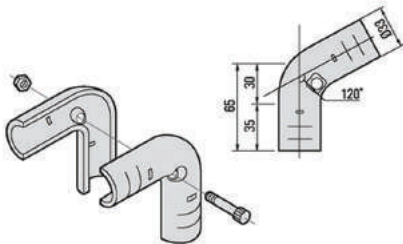

NJ-20

N-20: 2Pcs Bolt and nut: 1 set

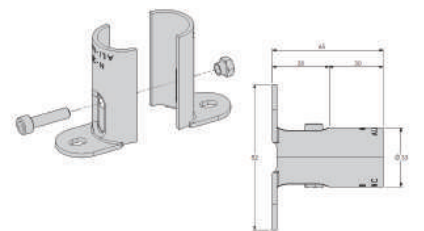
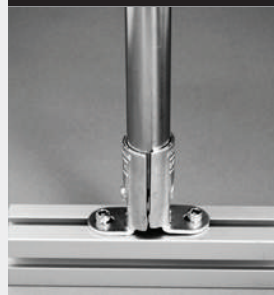

NJ-21

N-21A: 1Pc N-21B: 1Pc
Bolt: 1 Pc (M6 x10)

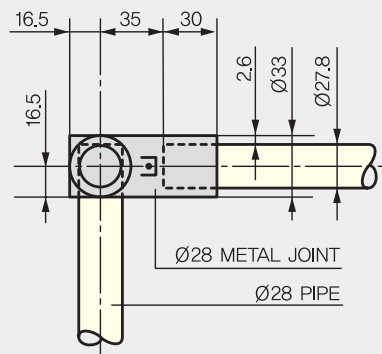
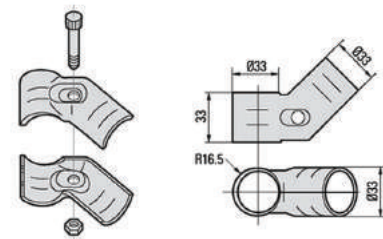

ALI Plastic Accessories / Connectors for 28mm Pipe

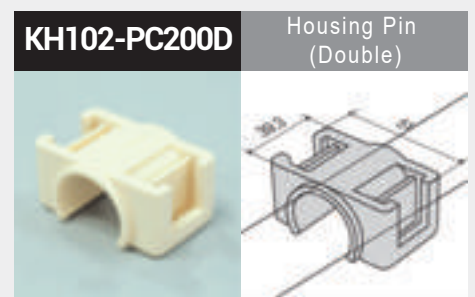
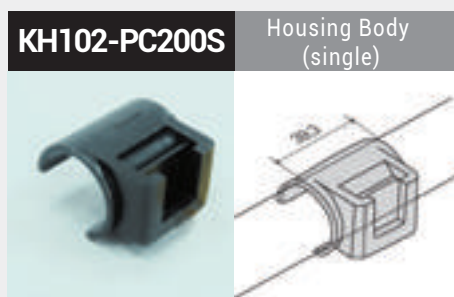
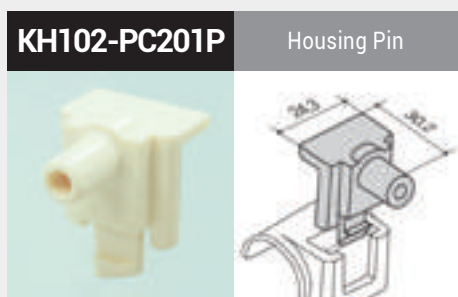
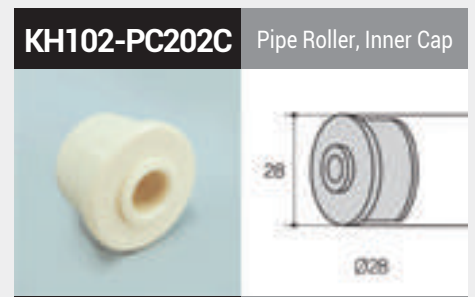
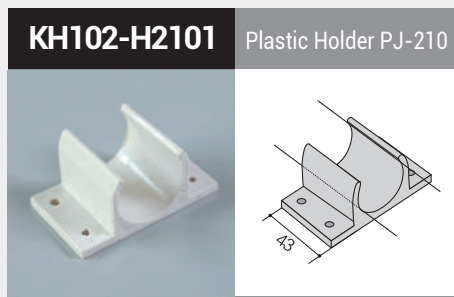
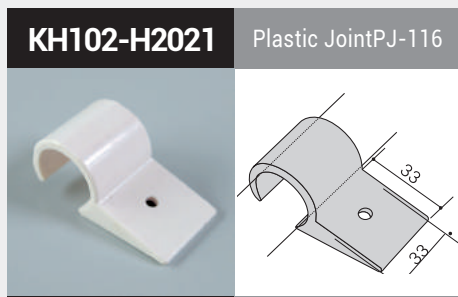
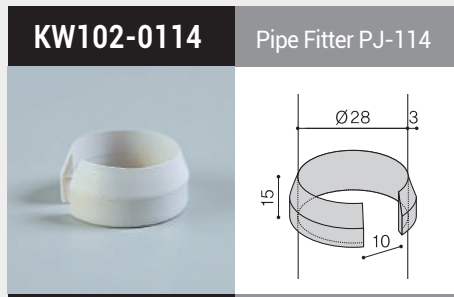
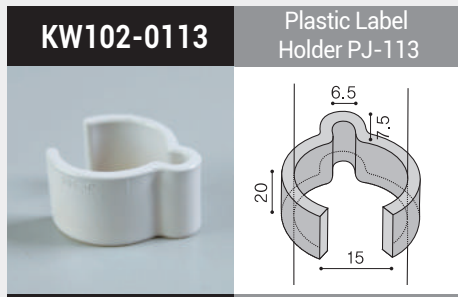
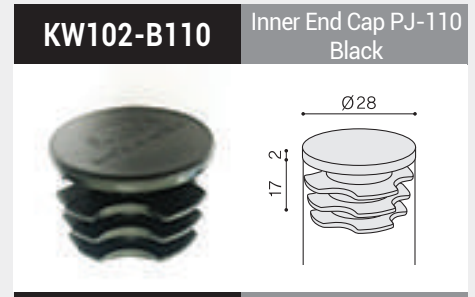
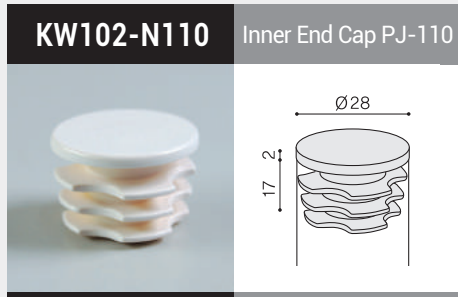

ALI Roller Conveyor 40/60/80 Type

KW105-40TP



40mm Black Roller Conveyor, Length: 4 meters

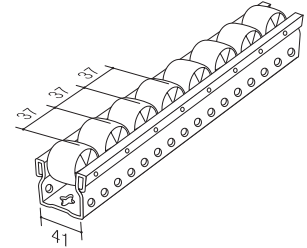
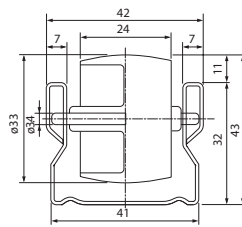

KW105-40TP-W

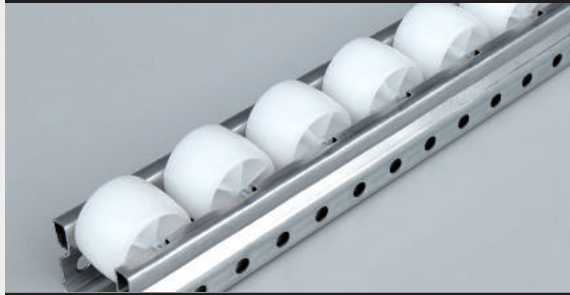

40mm White Roller Conveyor, Length: 4 meters

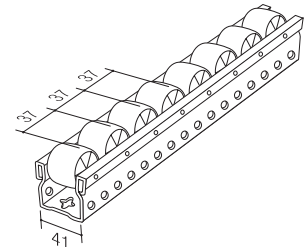
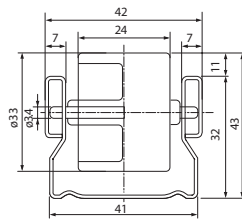

KW105-60TP



60mm White Roller Conveyor, Length: 4 meters

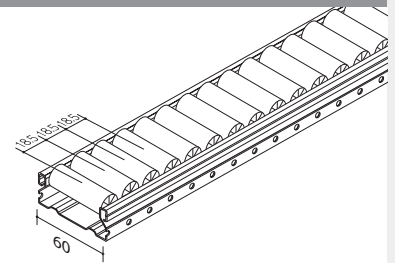
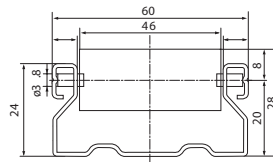

KW105-80TP

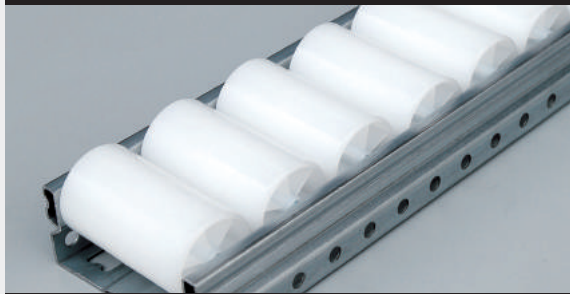

80mm White Roller Conveyor, length: 4 meters

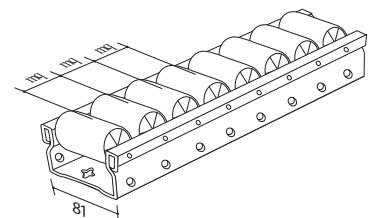
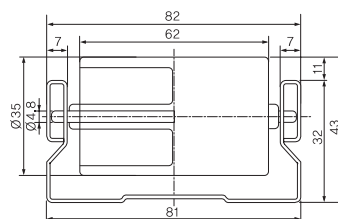

ALI ESD Roller Conveyor, 40 Type

KW105-M40GW



40mm ESD Guide Roller Conveyor, length: 4 meters

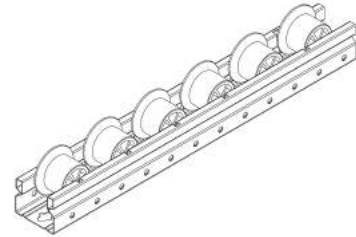
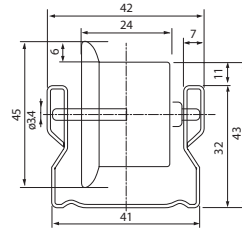

KW105-40TP-ESD



40mm ESD Roller Conveyor, Length: 4 meters

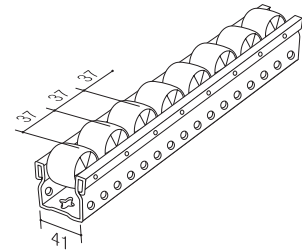
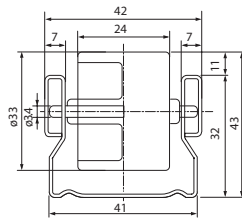

KW105-M40MR-ESD

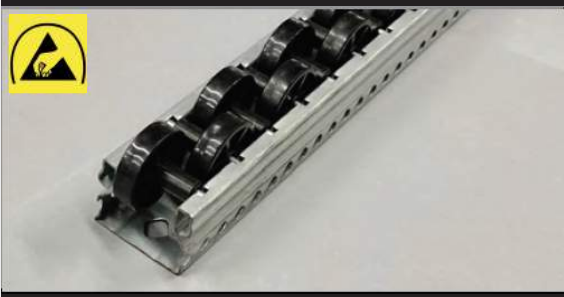

40mm ESD Multi-Roller Coveyor, Length: 4 meters

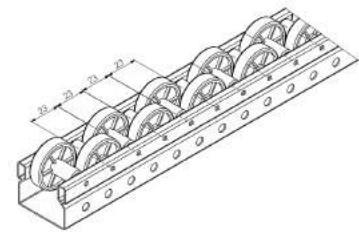
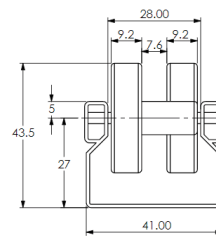

ALI Roller Conveyor Mounting Brackets

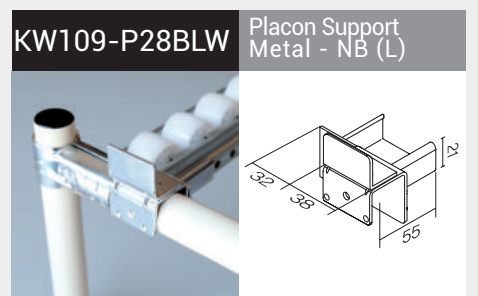
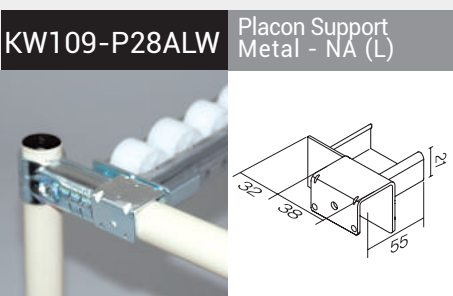
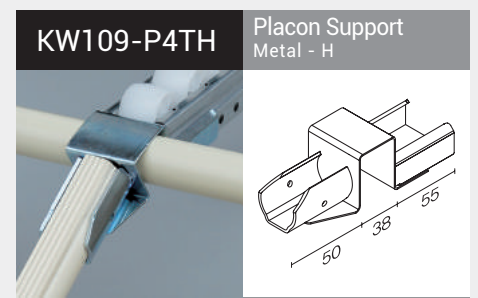
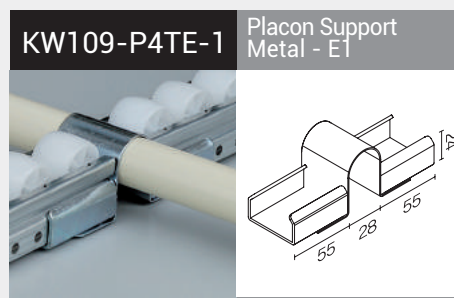
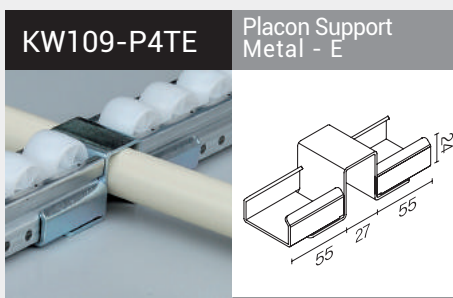
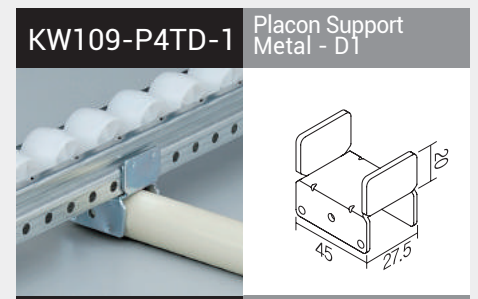
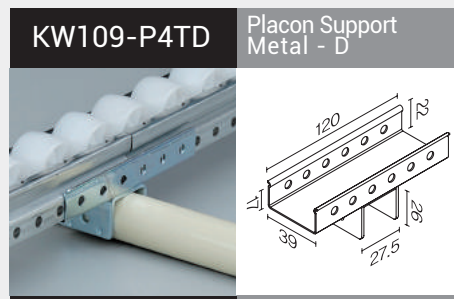
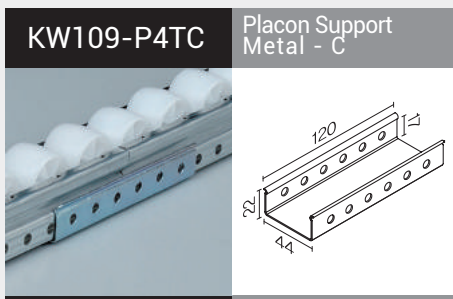
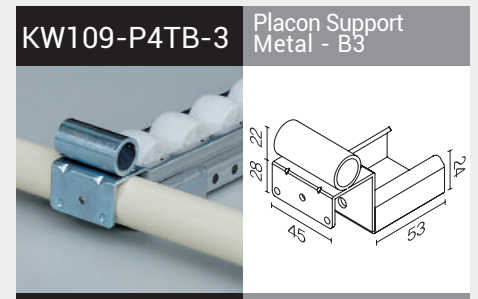
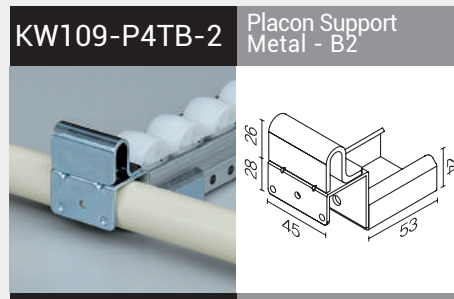
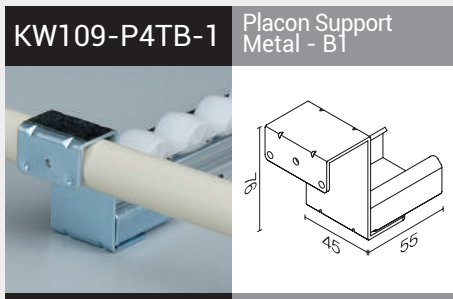
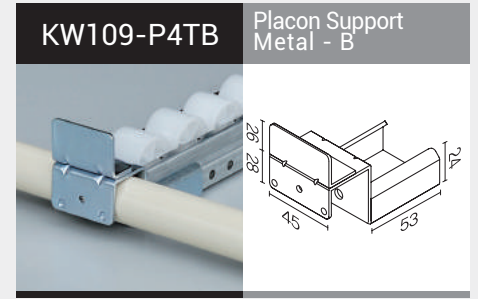
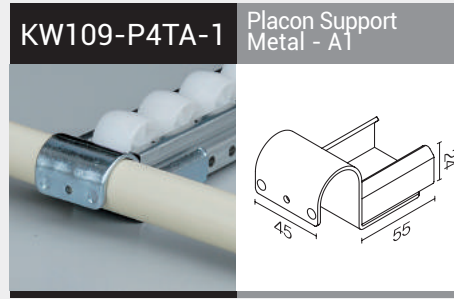
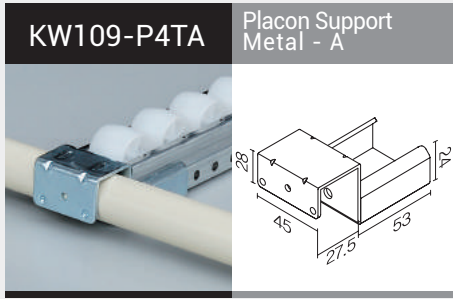

ALI Roller Conveyor Mounting Brackets

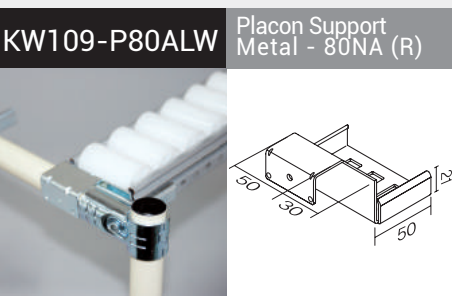
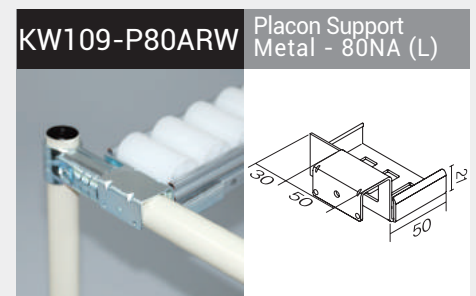
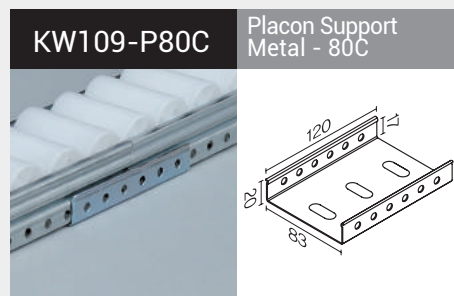
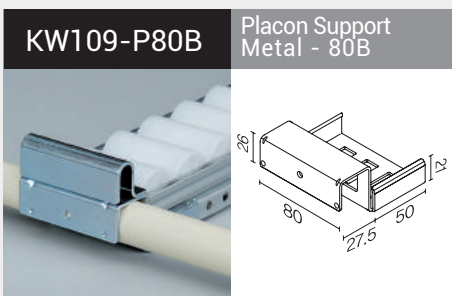
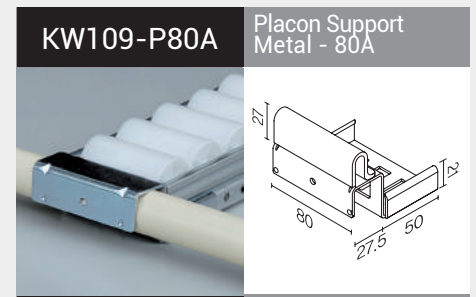
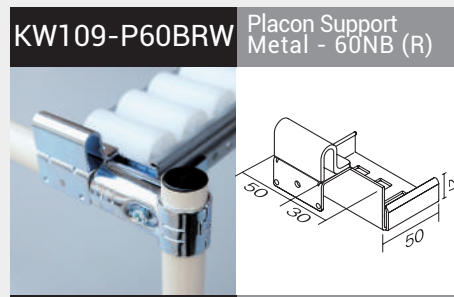
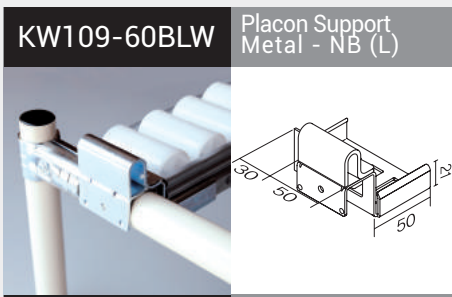
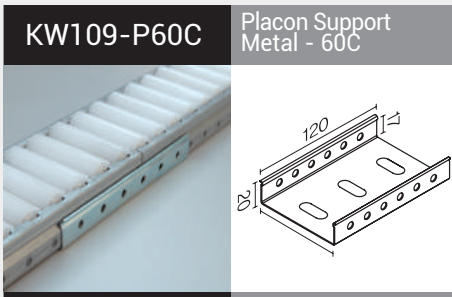
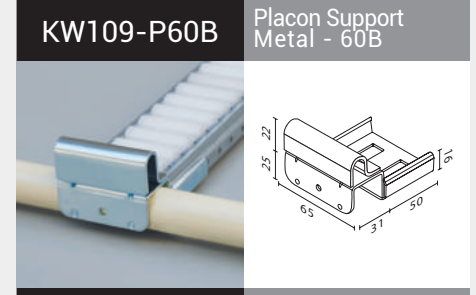
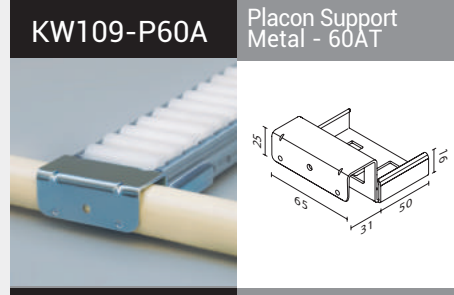
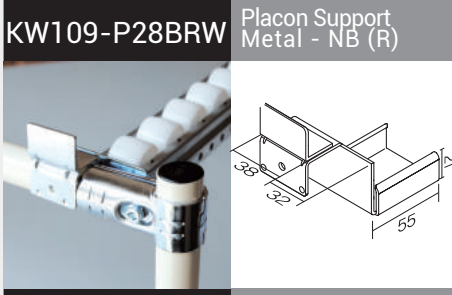

ALI Roller Conveyor Mounting Brackets for Aluminum

PS-30X30A

Placon Support
For profile 30x30

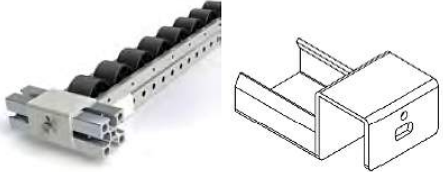

PS-30X30B

Placon Support
For profile 30x30

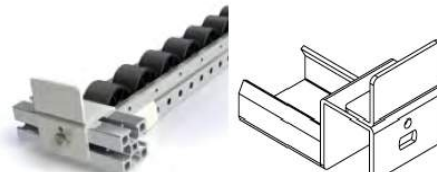

PS-40X40A

Placon Support
For profile 40x40

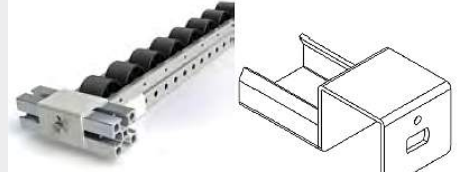

PS-40X40B

Placon Support
For profile 40x40

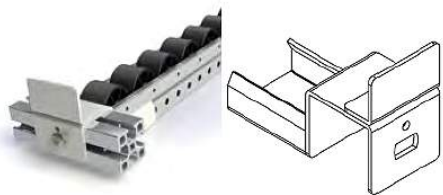

ALI-SCAN-H

ESD Acrylic Scan
Holder



ALI-TR20HD

Placon Support
Metal-60NA (R)



ALI Spare Parts & Accessories

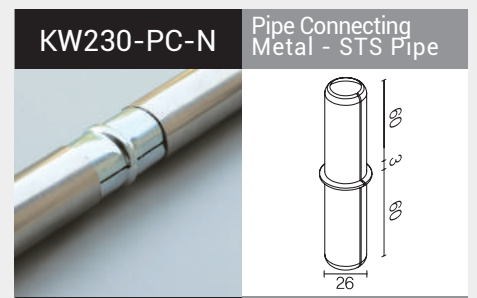
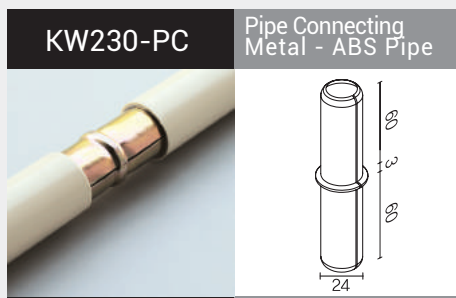
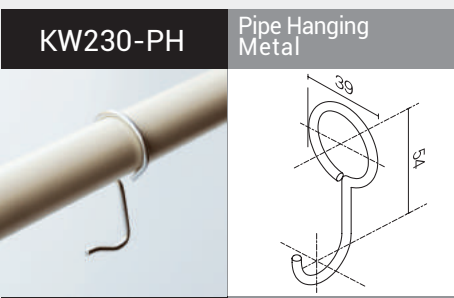
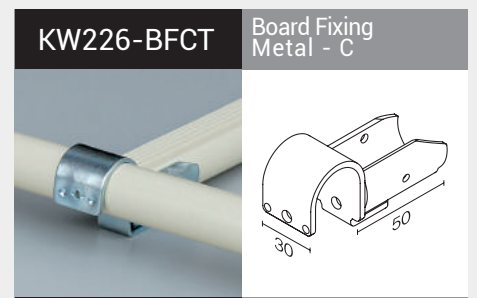
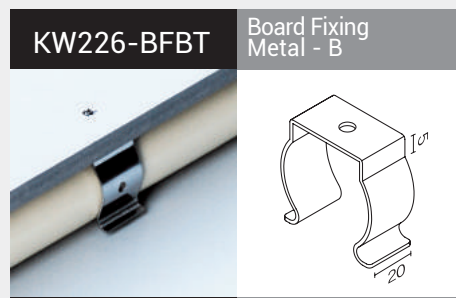
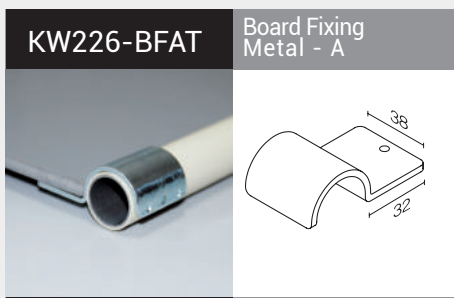
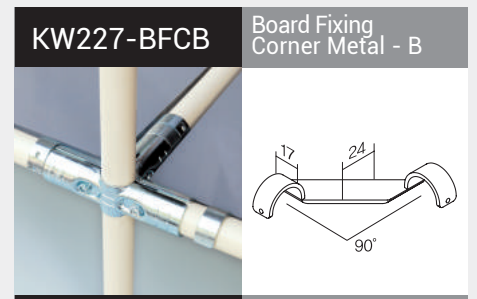
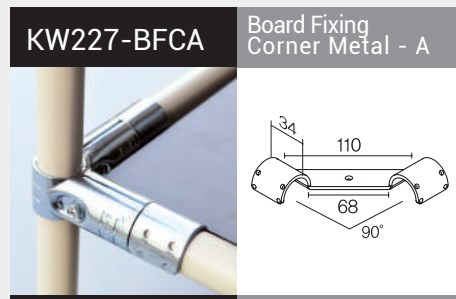
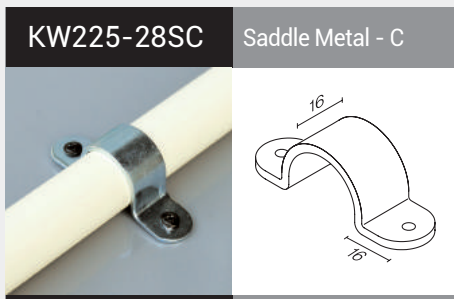
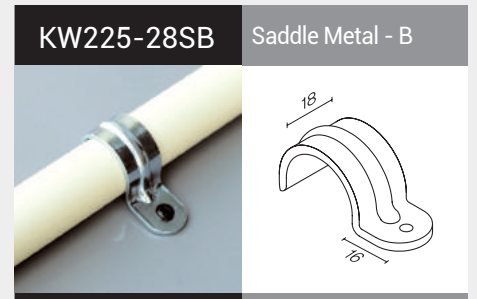
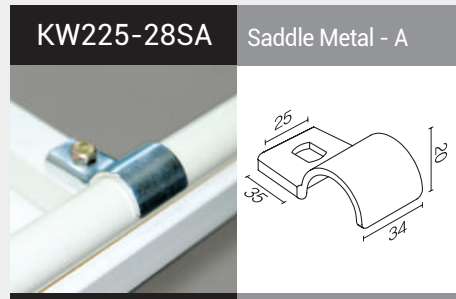
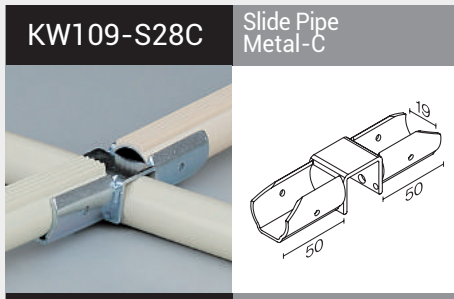
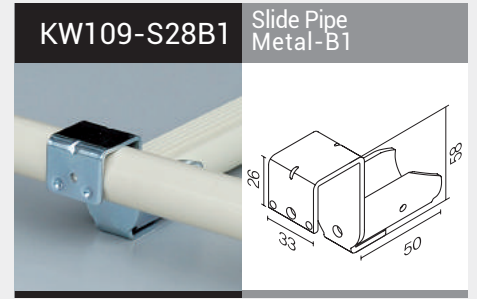
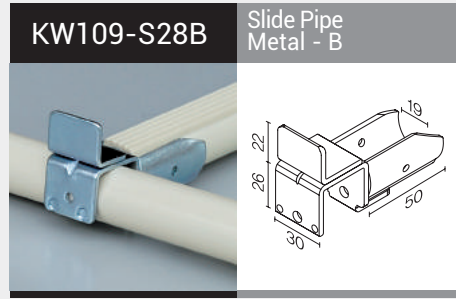
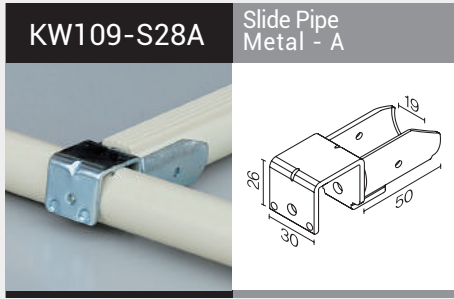

ALI Spare Parts & Accessories

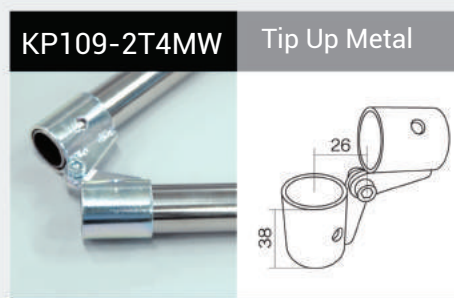
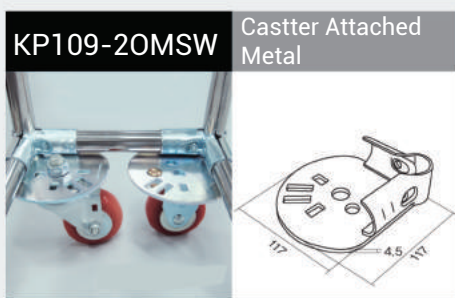
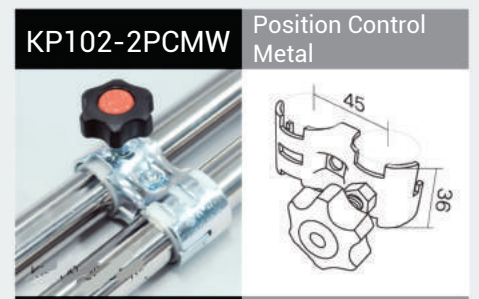
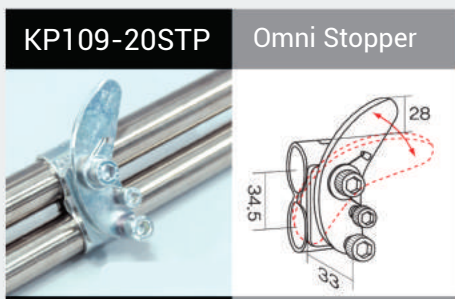
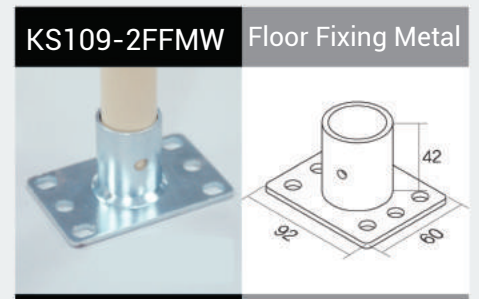
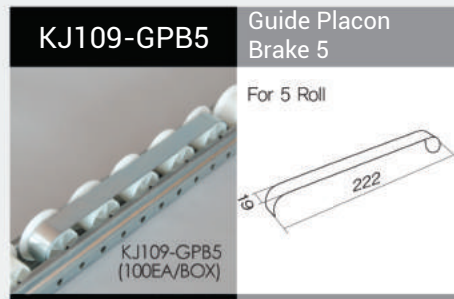
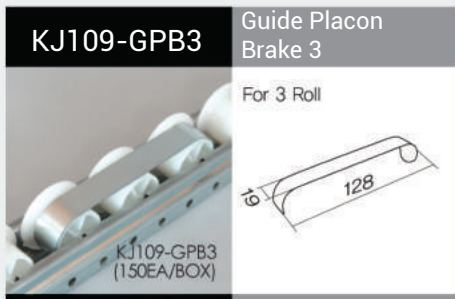
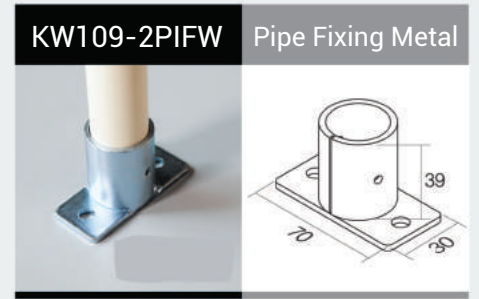
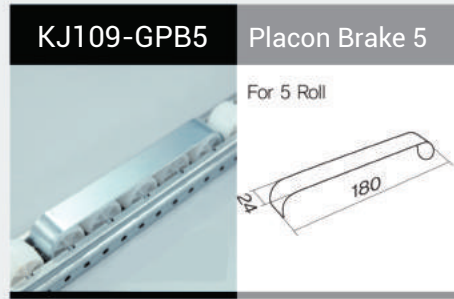
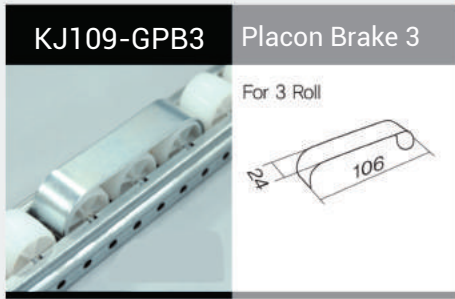

ALI Spare Parts & Accessories

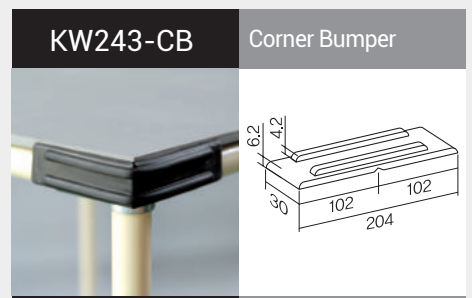
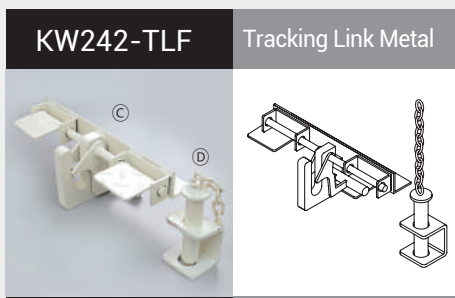
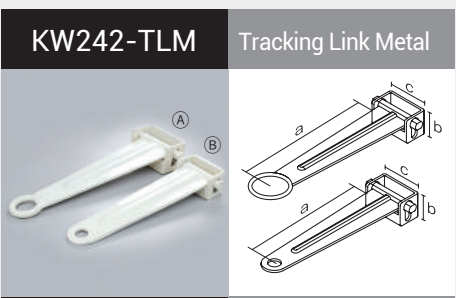
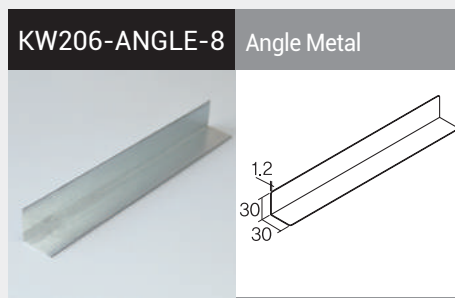
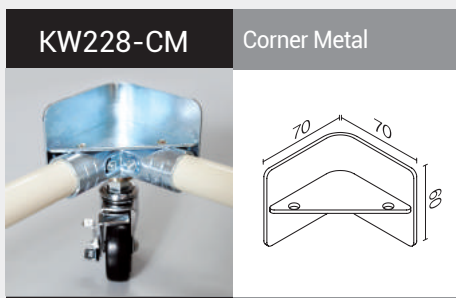
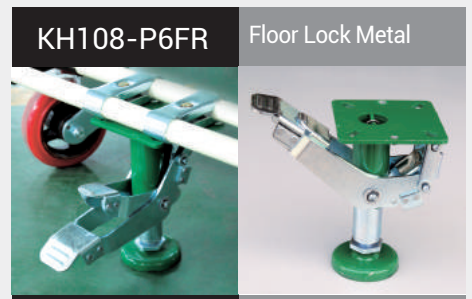
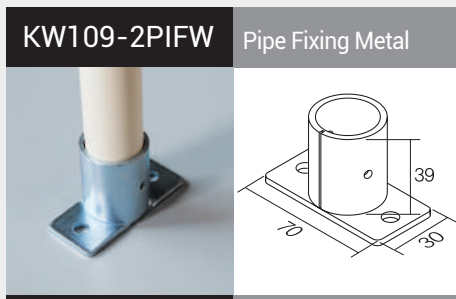
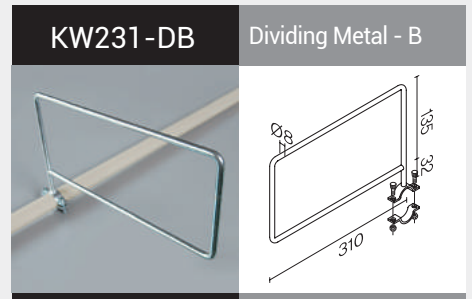
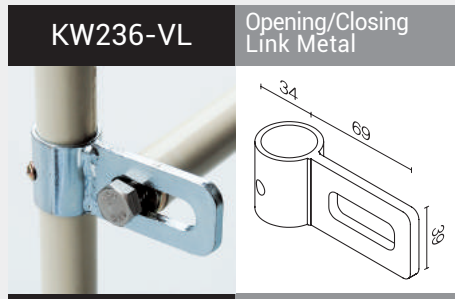
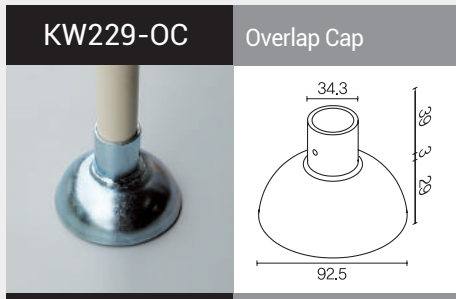
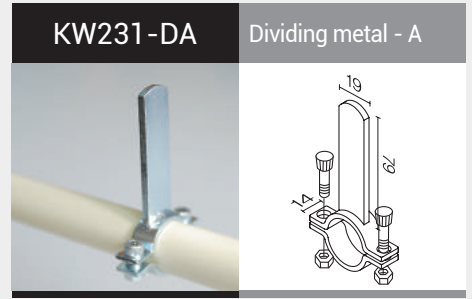
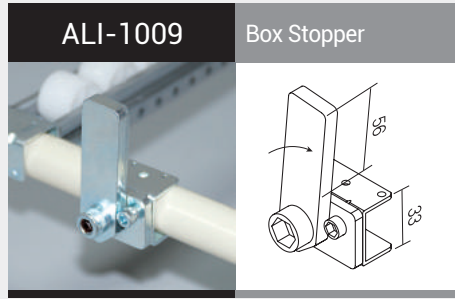
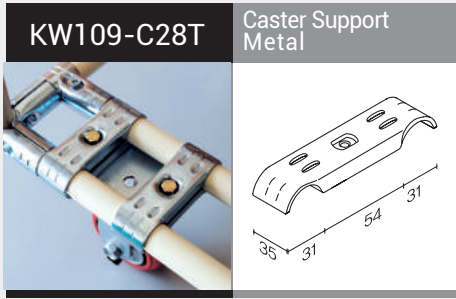

ALI Spare Parts & Accessories

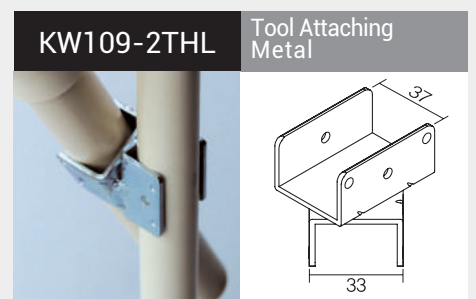
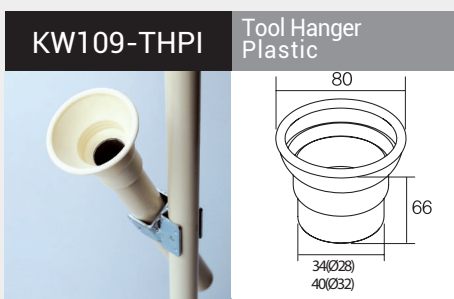
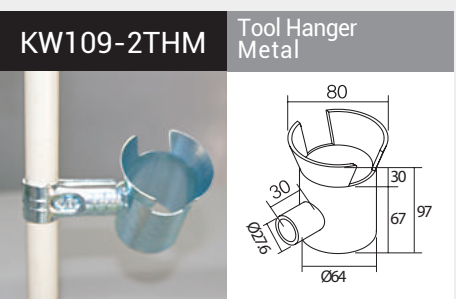
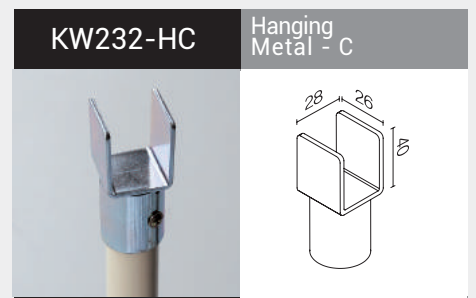
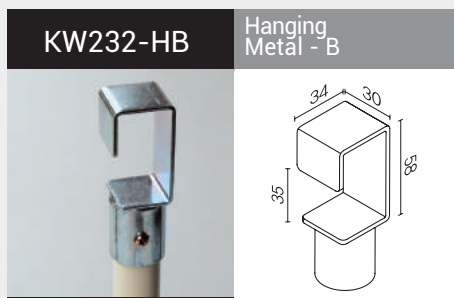
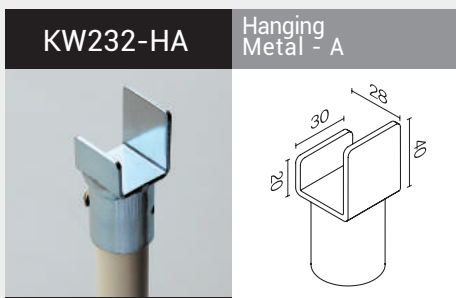
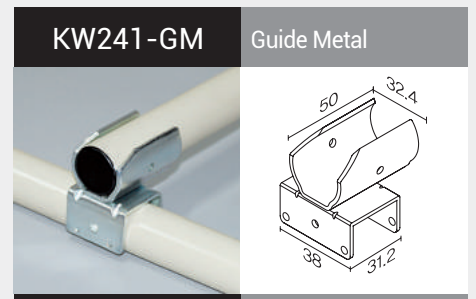
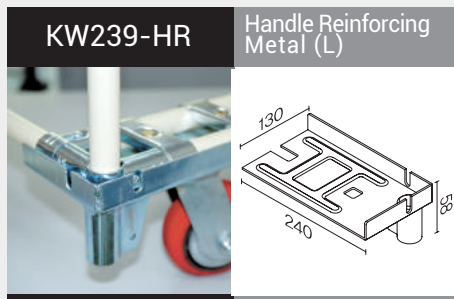
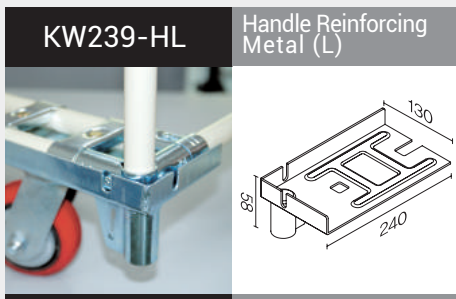
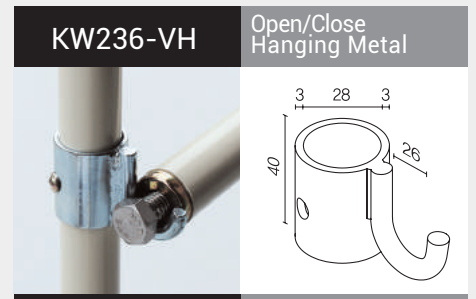
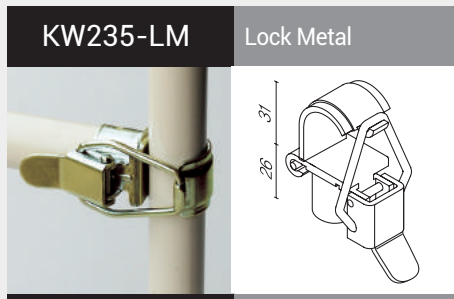
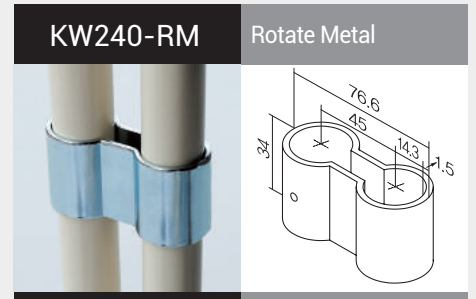
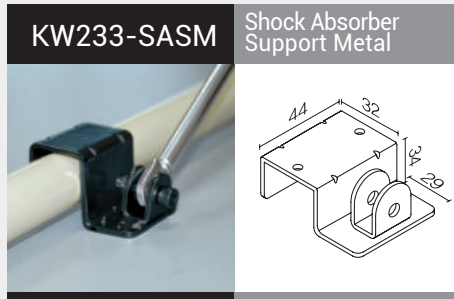
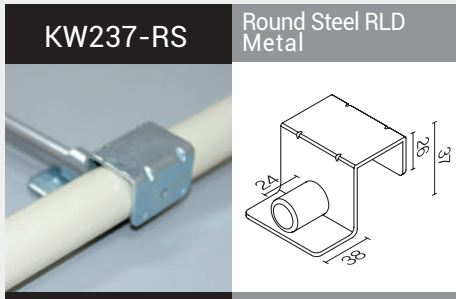

ALI Led & Fluorescent Lighting

ALI-LLT24

ALI-LLT48

ALI-FSLT-ASB

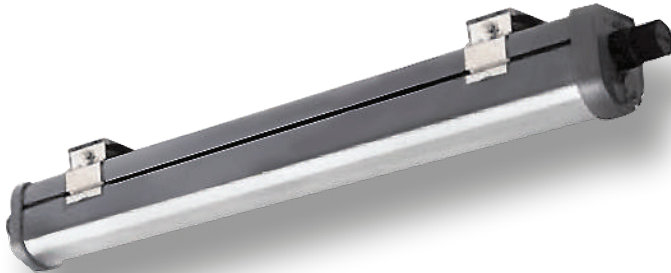

Specifications	ALI-LLT24	ALI-LLT48	ALI-FSLT-ASB
Features	LED Light	LED Light	Fluorescent
Length	24 inch	48 inch	36 inch
Connection	Power Cord Adapter		
Color	Natural White		
Color Temp	4000K	4300K	4100K
Lens	White Diffuser, UV - Stabil (PC)		-
Voltage	100 ~277 Vac		120 ~ 227 V
Power	15 W	40 W	25 W
Current	0.130 A	0.320 A	-
Operation Temp	~-20°C to ~+50°C, IP65, IP68, connct.		
Power Factor	1		
Efficacy	115 lm/W	110 lm/W	-
Lumens	1835 lm	4180 lm	2250 lm
Max Candela	430 cd	1010 cd	-
CRI	>82		>86
Viewing Angle	110° x 150°		-
Accessories Included	8 ft Power Cord 2 Hanging Brackets		2 F25T8 Lamps 8 ft Power Cord

ALI Table Top Material



HDPE Plastic

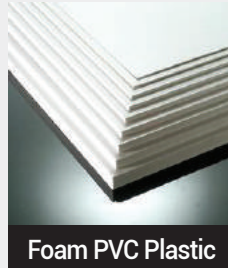

Foam PVC Plastic



Stainless Steel Sheet



MDP Melamine

Specifications	HDPE Plastic	Foam PVC Plastic	Stainless Steel Sheet	MDP Melamine
Sheet Size	4 x 8 ft	4 x 8 ft	48" x 120"	4 x 8 ft
Thickness	0.25, 0.50, 0.75 inch	0.25, 0.50, 0.75 inch	Different Gages	0.25, 0.50, 0.75 inch
Colors	White, Black	White	-	Different Colors
Material	High Density Polyethylene (HDPE)	Foam Polyvinyl Chloride Sheet	Stainless Steel 304	MDP
Finish	Glossy	-	2B	-

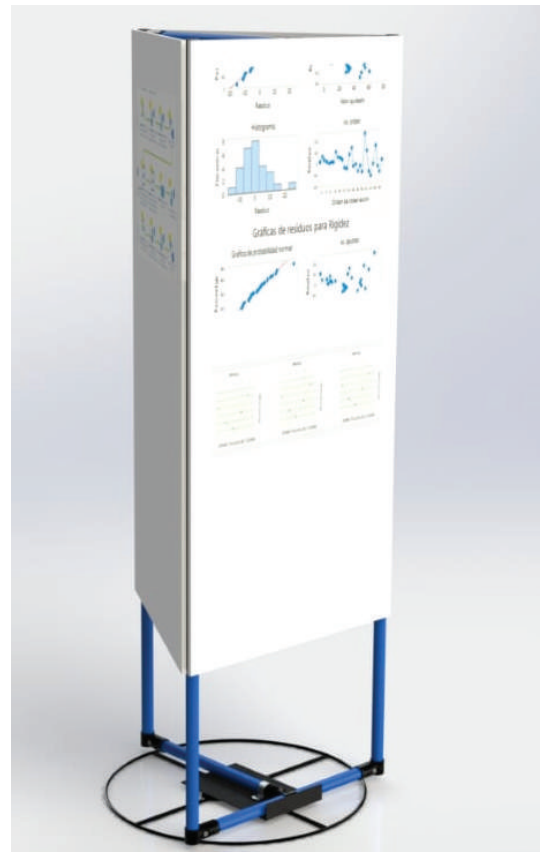

ALI Label holder & ESD EVA Foam

Part Number	A	B	C
KD213-150X60X1	150	60	1
KD213-170X105X1	170	105	1
KD213-170X65X1	170	65	1
KD213-180X85X1	180	85	1
KD213-220X110X12	220	110	2
KD213-260X120X2	260	120	2
KD213-300X120X2	300	120	2
KD213-310X225X2	310	225	2
KD213-60X305X2	60	305	2
KD213-430X320X2	430	320	2
KD213-150X60X1	150	60	1
KD213-430X320X4	430	320	4

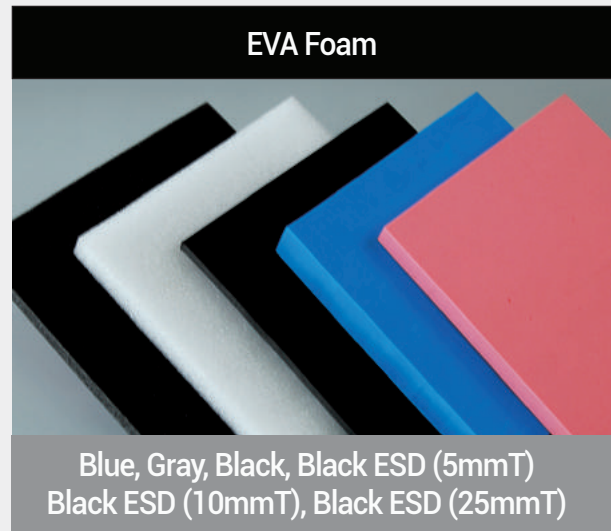
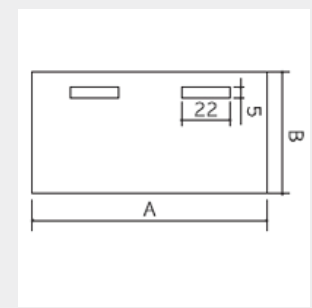
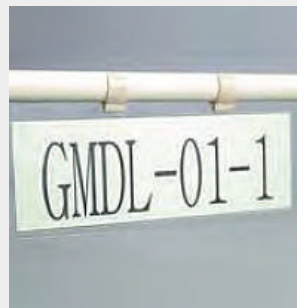
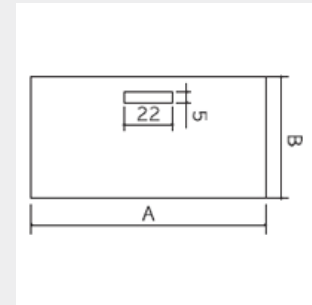
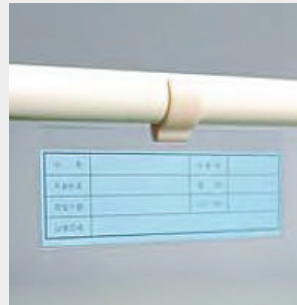

ALI Feet Levelers

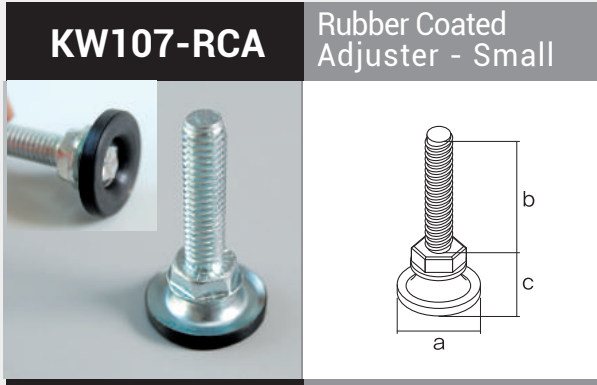

Part Number	A	B	C	Steam Spec.
KW107-RCA	38	50	21	1/2 x 12 UNC

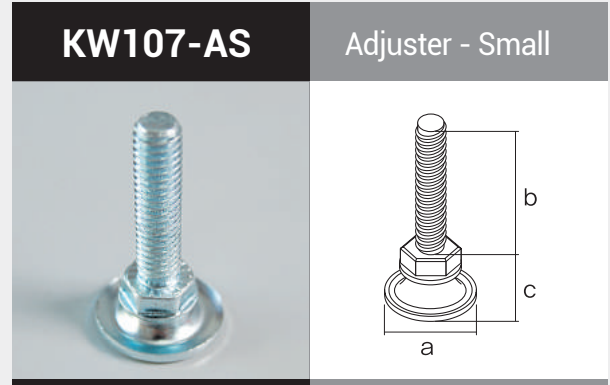

Part Number	A	B	C	Steam Spec.
KW107-AS	38	50	19	1/2 x 12 UNC

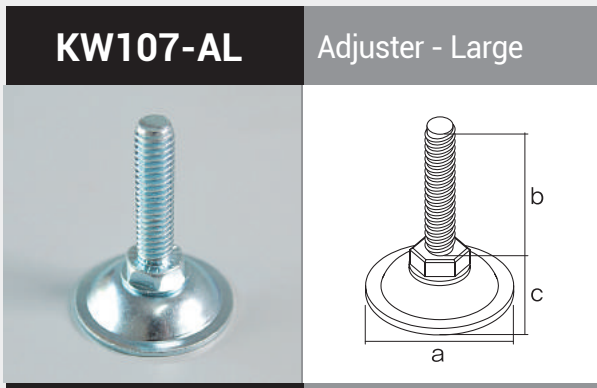

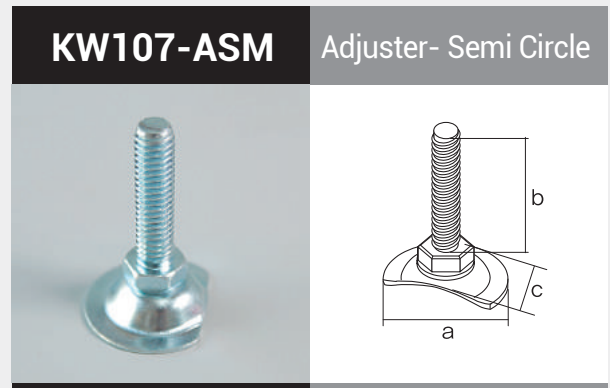

Part Number	A	B	C	Steam Spec.
KW107-AL	55	50	20	1/2 x 12 UNC
KW107-AL-100	38	100	20	1/2 x 12 UNC



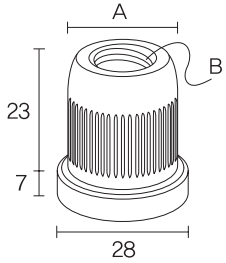

Part Number	A	B	C	Steam Spec.
KW107-ASM	42	50	20	1/2 x 12 UNC

ALI Metal Bushing for Feet Leveler

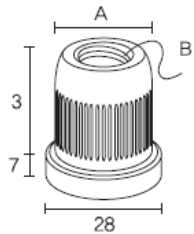
Metal Bushing	Diagram	Part Number	Classification	A (0)
		KW238-BN3T-A/J	28mm Coated Pipe	24
		B (Thread)		Use for
		1/2 x 12 UNC	2" Bushing for Adjuster	
		Part Number	Classification	A (0)
		KW238-BN3T	28mm Coated Pipe	24
		B (Thread)		Use for
		5/8 x 12 UNC	3" Bushing for 3" Caster	

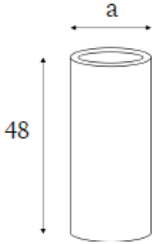



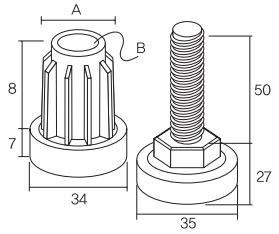

Metal Bushing	Diagram	Part Number	Classification	A (0)
		KW238-BN3T-A/J-N	28mm SS Pipe	26
		B (Thread)		Use for
		1/2 x 12 UNC	2T" Bushing for Adjuster 3/8	
		Part Number	Classification	A (0)
		KW238-BN3T-N	28mm SS Pipe	26
		B (Thread)		Use for
		5/8 x 12 UNC	3" Bushing for 3" Caster	

Plastic Bushing	Diagram	Part Number	Classification	A (0)
		KW238-RB-21	28mm Coated Pipe	21
		B (Thread)		Use for
		1/2 x 12 UNC	Rubber Bushing for Coated Pipe	
		Part Number	Classification	A (0)
		KW238-RB-25	28mm SS Pipe	25
		B (Thread)		Use for
		1/2 x 12 UNC	Rubber Bushing for SS Pipe	







Plastic Adjuster	Diagram	Part Number	Classification	A (0)
		KW213-PABNK	28mm Coated Pipe	24
		B (Thread)		Use for
			A/D Bolt (Black)	
		Part Number	Classification	A (0)
		KW213-PABNO	28mm SS Pipe	25
		B (Thread)		Use for
			A/D Bolt (Orange)	

ALI ESD Caster - Stem/ Insert Type



ESD Stem, Swivel Casters with Brake							
Part Number	Desc	 inch	 STEM SPEC	 mm	 mm	 mm	 kg
KS107-S3-BK-ESD	Swivel w/Brake	3"	M12	35	72	110	80
KS107-S4-BK-ESD	Swivel w/Brake	4"	M12	32	86	135	100
KS107-S5-BK-ESD	Swivel w/Brake	5"	M12	32	97	160	120





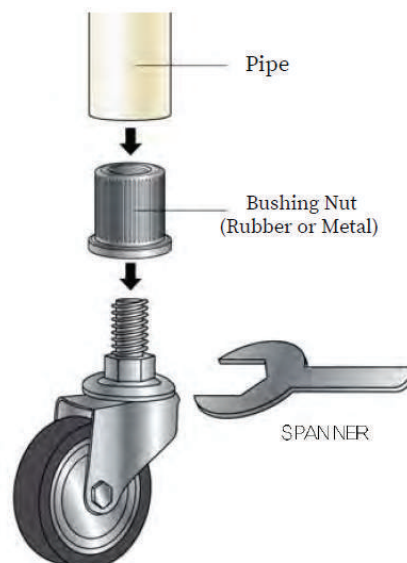

ESD Stem Casters No Brake							
Part Number	Desc	 inch	 STEM SPEC	 mm	 mm	 mm	 kg
KS107-S3-NB-ESD	Swivel	3"	M12	35	72	110	80
KS107-S4-NB-ESD	Swivel	4"	M12	32	135	100	100
KS107-S5-NB-ESD	Swivel	5"	M12	32	97	160	120









ALI ESD Casters - Plate Type

ESD Plate Type Caster, Swivel with Brake

Part Number	Desc	 inch	 mm	 mm	 kg	 mm	 mm
KS108-P3-BK-ESD	Swivel w/Brake	3"	116	108	80	92x62	76.5x44.5
KS108-P4-BK-ESD	Swivel w/Brake	4"	116	132	100	92x62	76.5x44.5
KS108-P5-BK-ESD	Swivel w/Brake	5"	116	157	120	92x62	76.5x44.5



ESD Plate Type Caster, Fixed, No Brake

Part Number	Desc	 inch	 mm	 mm	 kg	 mm	 mm
KS108-P3-FX-ESD	Fixed	3"	116	108	80	92x62	76.5x44.5
KS108-P4-FX-ESD	Fixed	4"	116	132	100	92x62	76.5x44.5
KS108-P5-FX-ESD	Fixed	5"	116	157	120	92x62	76.5x44.5

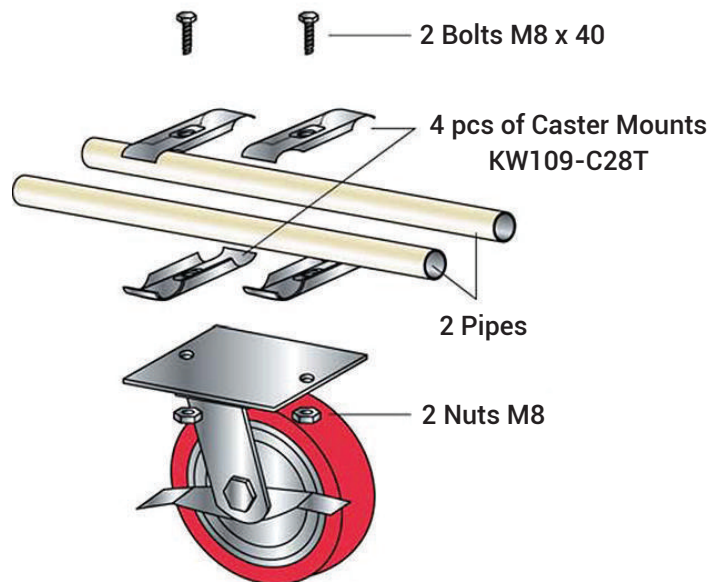

ALI Heavy Duty Casters & Accessories

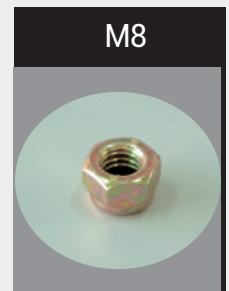
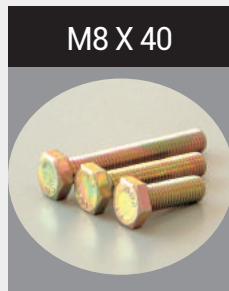
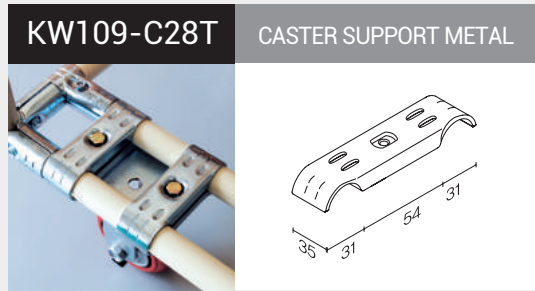
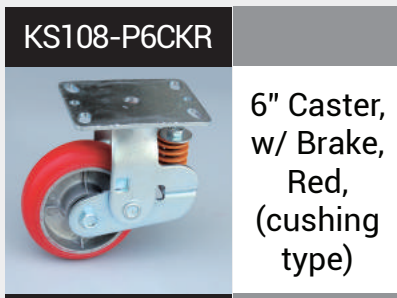

Casters Load Capacity

Wheel (mm)	Wheel Width (mm)	Total Height (mm)	Bearing Version (mm)	Load Capacity (kg)	Plate Size (mm)	Bolt Hole Spacing(mm)		Bolt Hole (mm)	Offset (mm)	Wheel Materials
						A	B			
100	38	136	Roller	200	104x84	90	42	9	80	R

Wheel (mm)	Wheel Width (mm)	Total Height (mm)	Bearing Version (mm)	Load Capacity (kg)	Plate Size (mm)	Bolt Hole Spacing(mm)		Bolt Hole (mm)	Offset (mm)	Wheel Materials
						A	B			
125	45	160	Roller	250	120x100	106	50	9	102	R

Wheel (mm)	Wheel Width (mm)	Total Height (mm)	Bearing Version (mm)	Load Capacity (kg)	Plate Size (mm)	Bolt Hole Spacing(mm)		Bolt Hole (mm)	Offset (mm)	Wheel Materials
						A	B			
150	48	190	Roller	300	120x100	106	50	9	114	R

Wheel (mm)	Wheel Width (mm)	Total Height (mm)	Bearing Version (mm)	Load Capacity (kg)	Plate Size (mm)	Bolt Hole Spacing(mm)		Bolt Hole (mm)	Offset (mm)	Wheel Materials
						A	B			
150	48	200	Ball bearing	300	160x115	137	57	12	129	R

Plate type casters assembly

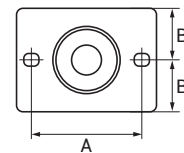
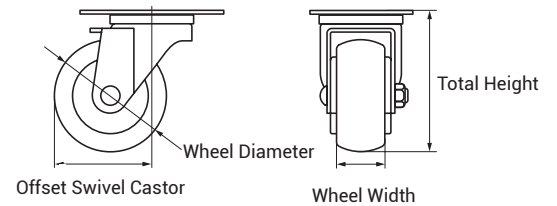
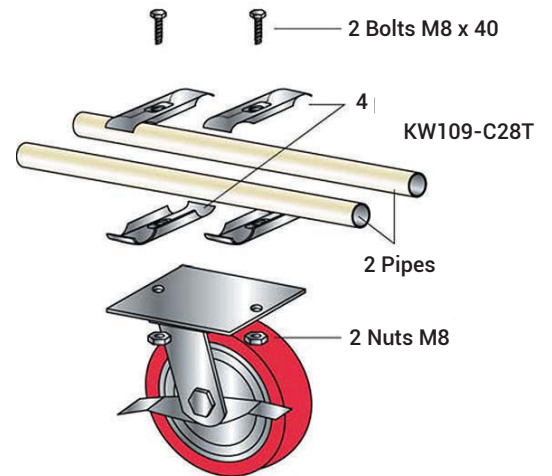

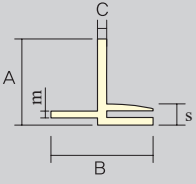

ALI Plastic Angle Accessories

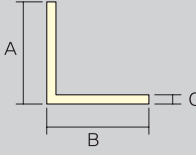
Diving Plastic Angle: 4 Meters	Diagram	Part Number	A	B	C	Color
		KW206-D50x55x3w	50	55	3	White
		KW206-D70x75x3w	70	75	3	White
		KW206-D100x90x3w	100	90	3	White

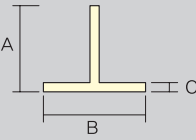
L-Type Plastic Angle: 4 Meters	Diagram	Part Number	A	B	C	Color
		KW206-0001L	30	50	3	White
		KW206-0003L	50	50	5	White
		KW206-0008L	100	50	5	White
		KW206-0009L	50	50	5	White

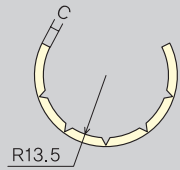
T-Type Plastic Angle: 4 Meters	Diagram	Part Number	A	B	C	Color
		KW206-T100x60x5w	50	55	3	White

Diving Plastic Angle: 4 Meters	Diagram	Part Number	A	B	C	Color
		KW202-285GY	·	·	33	Gray
		KW202-285 IV	·	·	33	Ivory

Diving Plastic Angle: 4 Meters	Diagram	Part Number	A	B	C	Color
		KW207-A96*1*1	·	·		Silver
		KW207-A96*2*2	·	·		Silver

Technical Specifications - Calculation of Pipe Length

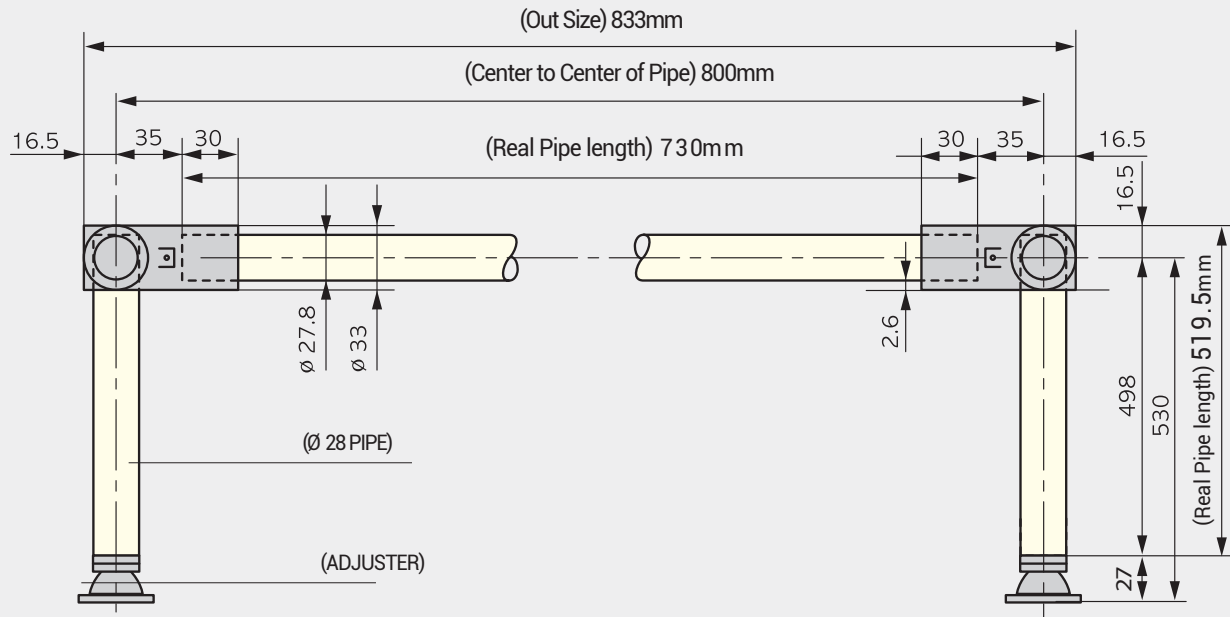

Horizontal Pipe Length Calculation

- 800 — Center to Center Length
- 70 — Pipe Length to Join Center Length

- 730** — Actual Pipe Length

Vertical Pipe Length Calculation

- 530 — Adjuster End to Joint Center Length
- 27 — Length Between the End Pipe and of Adjuster
- +16.5 — Center of Joint to End of Joint Length

- 519.5** — Actual Pipe Length

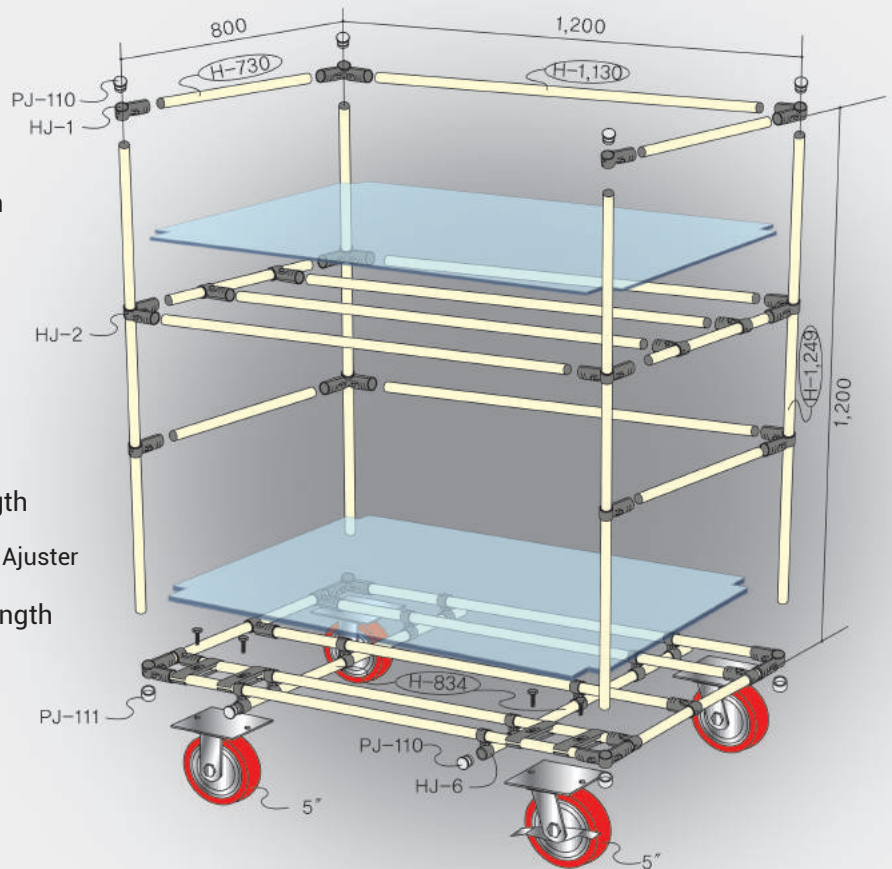

ALI Tools & Fasteners

M6 x 25



Bolt for Metal Joints

M8 x 25



Bolt for Caster Mount

M6



T- Nut for Metal joints

M8



Nut for Caster Mount

1132125



Flat Head Self-drilling Screw

0148422



Self-drilling Screw

76458918



Hand Deburring Tool

83671800



5m Metric Tape Measure

23331760



5mm Allen Hex Key

ALI-007



Rubber Mallet

ALI-1052W



Spanner Key

ALI-1086



Pipe Hand Cutter

70101704



Power Strip; 36" L, 12 Outlets

70231845



Bin Holder Panel
35-3/4" x 5/16" x 19"

30148



Bin Holder, 48" L,
110 Lbs Capacity

ALI-TR20HD



Tool Rail Heavy Duty

Display Boards, Flow Racks, Workstation, Push Carts & Production Lines



ALI 3D Design Services



2

1

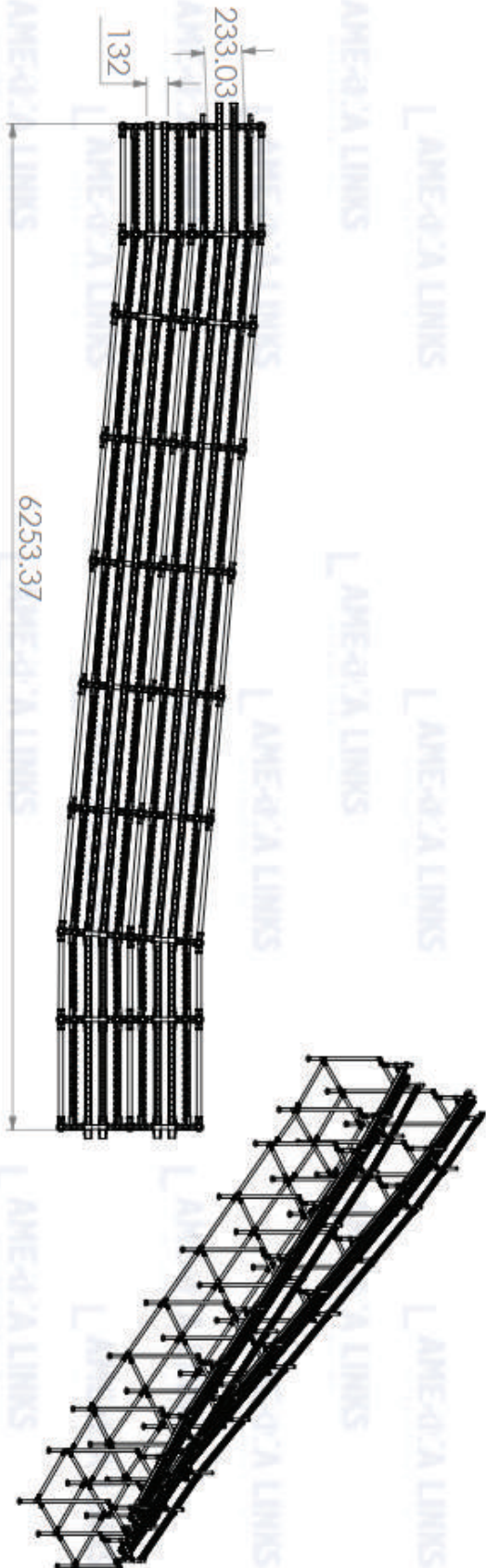

B

B

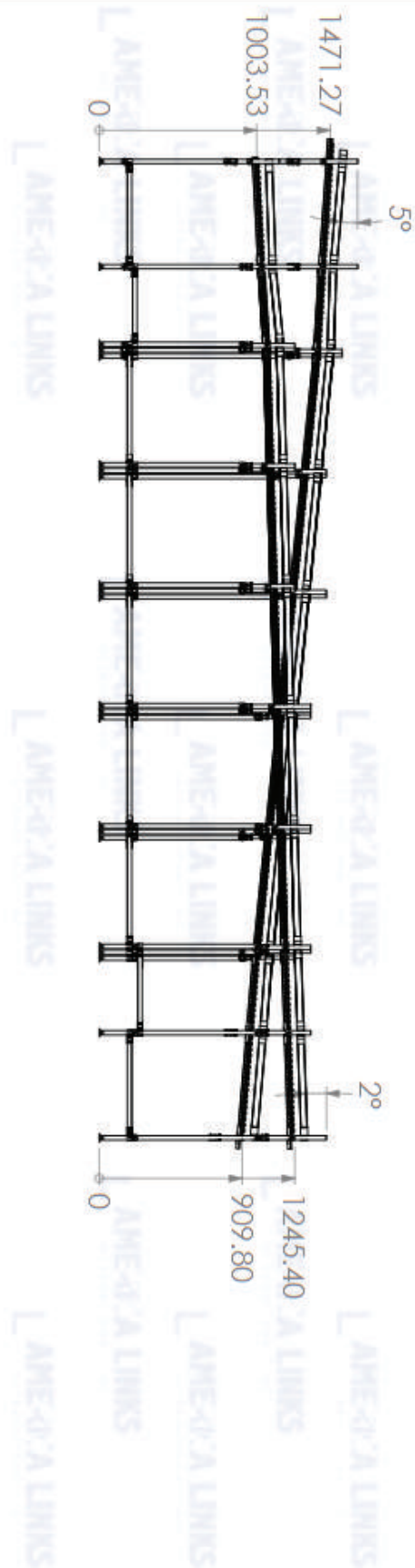

A

A



www.amerit-links.com
Email: info@amerit-links.com

Drawing Title:

ALL-JNS-0223-N0030

Notes:

The information in this drawing belongs exclusively to America Links Int'l, Inc. Distribution complete or partial is strictly prohibited without the prior written authorization from America Links Int'l, Inc. Dimensions are in millimeters. Tolerances: ±0.5mm

REV:

A

CAD File #:

ALL-JNS-0223-N0030

Scale:

1:40

Approved by:

2

1

2

1

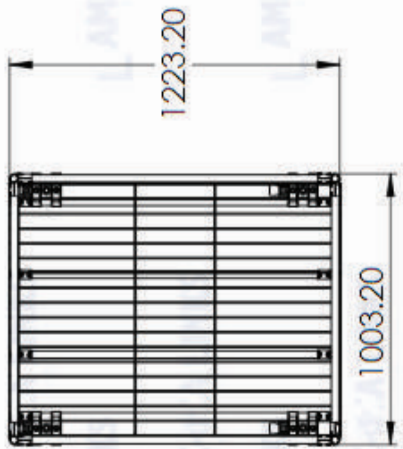

B

B

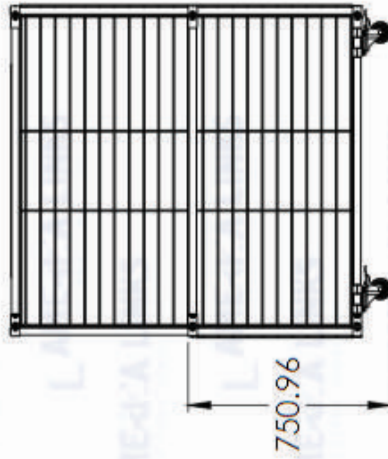
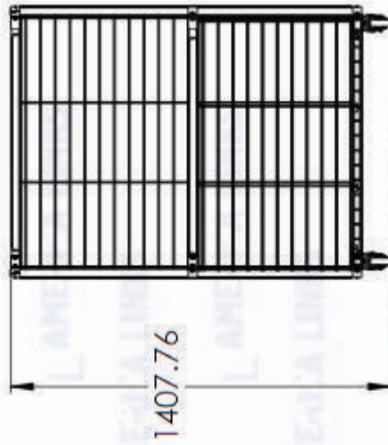

A

A



www.ameri-links.com
Email: info@ameri-links.com

Drawing Title:

ALI-CLE-0326-N0010

Notes:

The information in this drawing belongs exclusively to America Links Int'l, Inc. Distribution complete or partial is strictly prohibited without the prior written authorization from America Links Int'l, Inc. Dimensions are in millimeters. Tolerances: ±.5mm

REV:

A

CAD File #:

ALI-CLE-0326-N0010

Scale:

1:25

Approved by:

2

1

2

1

2

1

Nota: Incluir
Balancin, tapete, bines, seccion ESD pulsera

B

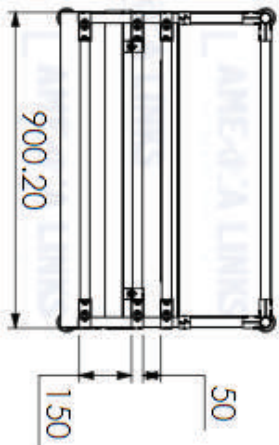

A

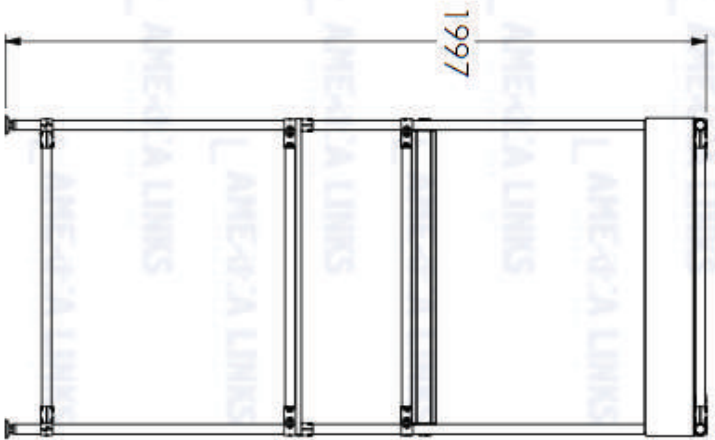

B

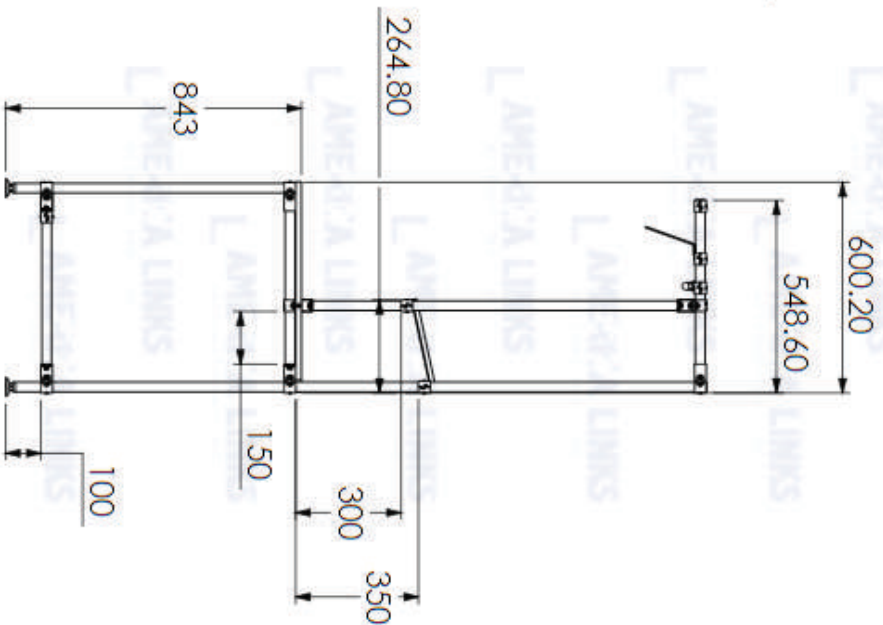

A

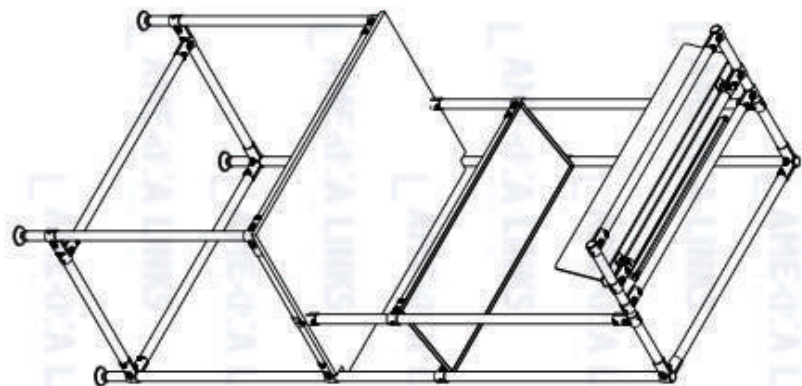

www.ameri-links.com
 Emali: Info@ameri-links.com

Drawing Title:

ALL-ALM-0607-N0010

Notes:

The information in this drawing belongs exclusively to America Links Int'l. Inc. Distribution complete or partial is strictly prohibited without the prior written authorization from America Links Int'l. Inc. Dimensions are in millimeters. Tolerances: ±5mm

REV:

A

CAD File #:

ALL-ALM-0607-N0010

Scale:

1:20

Approved by:

2

1



ALIMEX ELECTRONICS

S. A. D E C. V.



Guadalajara Office
Av Antiguo Camino
Real a Colima 100-14B
Col. Los Cajetes
Zapopan, Jalisco 45234

(33) 3804 1219 Tel

info@ameri-links.com

